

EE660

Low Air Velocity Sensor

The EE660 is optimized for highly accurate measurement of very low air velocity in laminar flow control and special ventilation applications, for instance in clean rooms.

Excellent Measurement Performance

The E+E thin film sensing element employed in EE660 operates on the hot film anemometer principle, which stands for excellent accuracy down to 0.15 m/s (30 ft/min), high insensitivity to pollution and low angular dependency.

Analogue and Digital Outputs

The air velocity measured data is available as current and voltage outputs, on the RS485 interface with Modbus RTU or BACnet protocol, as well as on the optional display.

Easy Configuration and Adjustment

The EE660 is user configurable with jumpers on the electronics board or via software. An optional configuration adapter and the free EE-PCS Product Configuration Software facilitate the adjustment of EE660 and the display setup.



Features

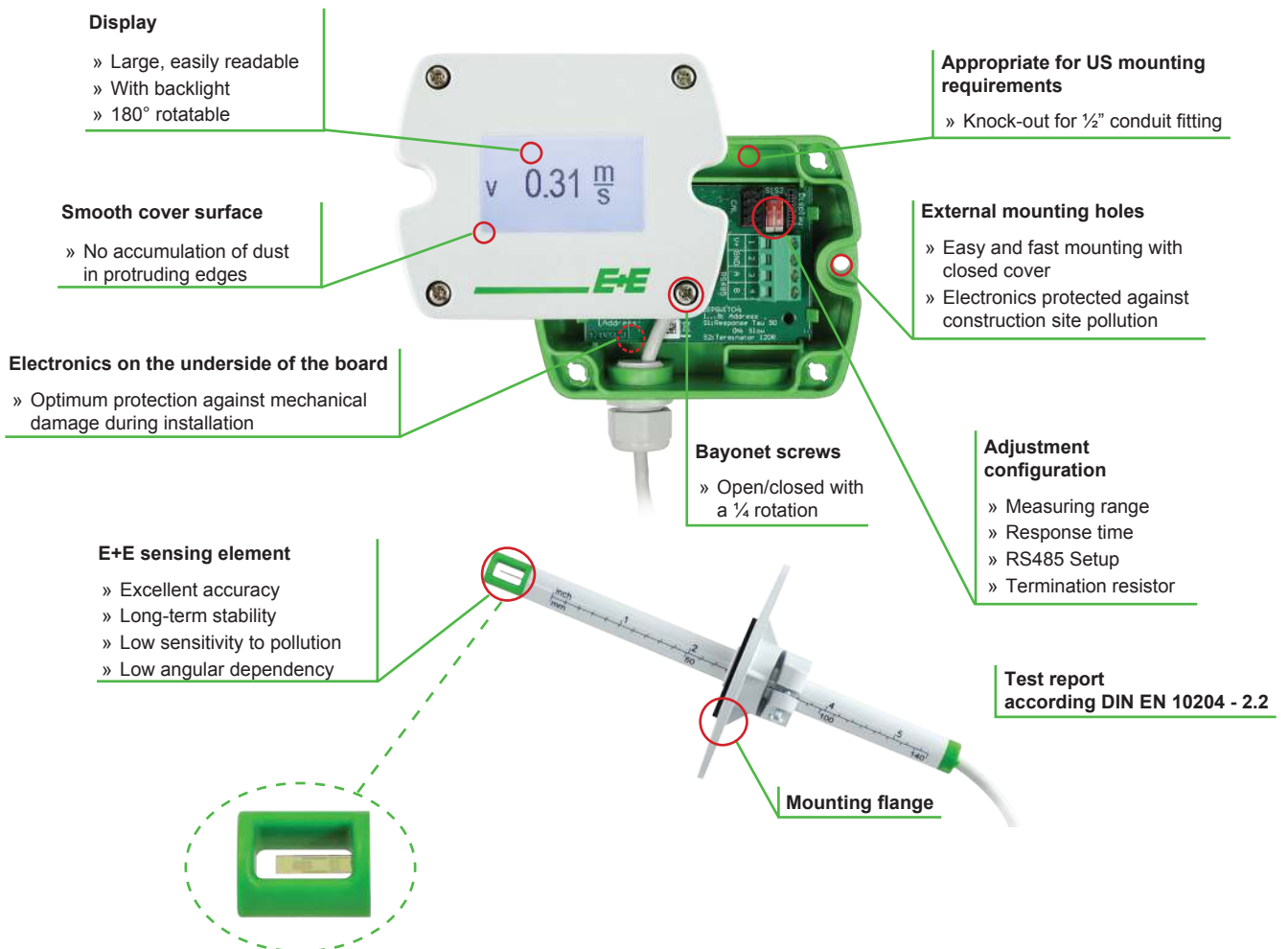

Technical Data

Measurand

Working range ¹⁾	0...1 m/s (0...200 ft/min)
	0...1.5 m/s (0...300 ft/min)
	0...2 m/s (0...400 ft/min)
Accuracy at 20 °C ²⁾ (68 °F), 45 % RH, 1013 hPa	0.15...1 m/s (30...200 ft/min) ± (0.04 m/s (7.9 ft/min) + 2 % of mv)
	0.15...1.5 m/s (30...300 ft/min) ± (0.05 m/s (9.8 ft/min) + 2 % of mv)
	0.15...2 m/s (30...400 ft/min) ± (0.06 m/s (11.8 ft/min) + 2 % of mv)
Response time τ_{90} ³⁾	typ. 4 sec or typ. 1 sec (at constant temperature)

Output

Analogue	0 - 10 V and 4 - 20 mA
0...1 m/s / 0...1.5 m/s / 0...2 m/s ¹⁾	-1 mA < I_L < 1 mA R_L < 450 Ω (linear, 3-wires)
Digital interface	RS485 with max. 32 devices on one bus
Protocol	Modbus RTU or BACnet MS/TP

General

Power supply (Class III) \diamond	24 V AC/DC \pm 20 %			
Current consumption (max.)	AC supply - no display	DC supply - no display	AC supply - with display	DC supply - with display
	Analogue output	74 mA rms	180 mA rms	85 mA
	Digital output	120 mA rms	-	-
Angular dependence	< 3% of the measured value at $ \Delta\alpha < 10^\circ$			
Electrical connection	screw terminals max. 1.5 mm ² (AWG 16)			
Cable gland	M16x1.5			
Electromagnetic compatibility	EN61326-1	EN61326-2-3	CE	
	Industrial Environment			
Housing material	Polycarbonate, UL94V-0 (with Display UL94HB) approved			
Protection class	Enclosure IP65 / NEMA4, remote probe IP20			
Temperature range	working temperature probe	-25 ... +50 °C (-13...122 °F)		
	working temperature electronic	-10 ... +50 °C (14...122 °F)		
	storage temperature	-30 ... +60 °C (-22...140 °F)		
Working range humidity	5...95 % RH (non-condensing)			

- 1) Selectable by jumper, only for analogue output
- 2) The accuracy statement includes the uncertainty of the factory calibration with an enhancement factor k=2 (2-times standard deviation).
The accuracy was calculated in accordance with EA-4/02 and with regard to GUM (Guide to the Expression of Uncertainty in Measurement).
- 3) Selectable by jumper (analogue) and slide switch (digital)

Dimensions mm (inch)

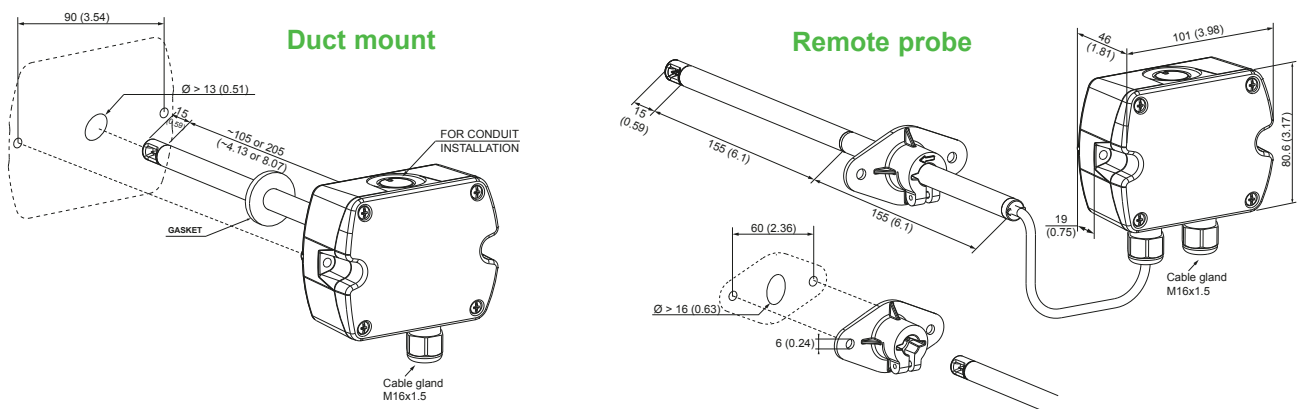

Ordering Guide

		EE660-		
Configuration	Model	duct mount	T2	
		remote probe	T3	
	Output	0-10 V and 4-20 mA	A7	
		RS485	J3	
	Probe length	100 mm (3.94")	L100	
		200 mm (7.88")	L200	
		300 mm (11.82")	L300	
Cable length		1 m (3.3 ft)	K1	
		2 m (6.6 ft)	K2	
		5 m (16.4 ft)	K5	
		10 m (32.8 ft)	K10	
Display	no display	no code		
	with display (only for analogue output A7)	D2		
Display unit	m/s	no code		
	ft/min	DA21		
Setup RS485	Protocol	Modbus RTU ¹⁾	P1	
		BACnet MS/TP ²⁾	P3	
	Baud rate		9600	BD5
			19200	BD6
			38400	BD7
		57600 ³⁾	BD8	
	76800 ³⁾	BD9		

1) Factory setting: Even Parity, Stopbits 1
 2) Factory setting: No Parity, Stopbits 1
 3) Only for BACnet MS/TP

Modbus Map see User Guide at www.epluse.com/ee660
 Product Implementation Conformance Statement (PICS) available at www.epluse.com/ee660

Order Examples

EE660-T3J3L300K1P1BD5

Model: remote probe
 Output: RS485
 Probe length: 300 mm (11.82")
 Cable length: 1 m (3.3 ft)
 Display: no display
 Protocol: Modbus RTU
 Baud rate: 9600

EE660-T2A7L200

Model: duct mount
 Output: 0-10 V and 4-20 mA
 Probe length: 200 mm (7.88")

Accessories

USB configuration adapter **HA011066**
 Product configuration software **EE-PCS** (free download: www.epluse.com/EE660)
 Power supply adapter **V03** (see data sheet Accessories)

