

AT9000 Advanced Transmitter

Flange type of Differential Pressure Transmitter

OVERVIEW

AT9000 Advanced Transmitter is a microprocessor-based smart transmitter that features high performance and excellent stability. Capable of measuring gas, liquid, and vapor, and liquid levels, it transmits 4 to 20 mA DC analog and digital signals according to the measured differential pressure.

It can also execute two-way communications between the communicator, thus facilitating self-diagnosis, range resetting, and automatic zero/span adjustment.

SFN, HART® and FOUNDATION Fieldbus are available.

* Refer to SS2-GTX00Z-0100 for FOUNDATION Fieldbus type for the items marked with [☆].

FEATURES

Excellent stability and high performance

- Long-term stability is proven in 500,000 installations worldwide.
- Unique characterization and composite semiconductor sensors realize excellent temperature and static pressure characteristics.

A diverse lineup

- A diverse flange lineup, ranging from 1 1/2 inch (40 mm) to 4 inches (100 mm), is available to meet user requirements.
- A wide variety of models, including those for standard differential pressure and high differential pressure, is available to meet user requirements.
- A wide variety of corrosion-resistant materials for wetted parts is also available.



Remote communication

- Two-way communication using digital output facilitates self-diagnosis, range resetting, automatic zero adjustment, and other operations.

China RoHS

This device is used in the Oil & Gas, Petrochemical, Chemical, Pulp & Paper, Food & Beverage, Machinery, Steel/Metal & Mining, and Automobile industries and therefore does not fall under the China RoHS Legislation.

If this device is used in semiconductor manufacturing equipment, labeling on the device and documents for the China RoHS may be required. If such documents are required, consult an Azbil Corp. representative.

HART® is a registered trademark of the FieldComm Group.

FOUNDATION™ is a registered trademark of the FieldComm Group.

PRODUCT APPROVALS [☆]**FM Explosionproof for Division System/
Flameproof for Zone System (Code F1)**

Explosionproof for Class I, Division 1, Groups A, B, C and D; Class I, Zone 1, AEx d IIC

Dust-Ignitionproof for Class II, III, Division 1, Groups E, F and G

T5 $-40\text{ °C} \leq T_{amb} \leq +85\text{ °C}$

Hazardous locations

Indoor/Outdoor Type 4X, IP67

Factory sealed, conduit seal not required for Division applications

Caution - Use supply wires suitable for 5 °C above surrounding ambient

FM Intrinsic Safety (Code F2)

IS/I, II, III/1/ABCDEFGH/T4; $-40\text{ °C} \leq T_{amb} \leq +60\text{ °C}$;

80395278, 80395279, 80395280; Entity; TYPE 4X; IP67

I/0/AEx ia/IIC/T4; $-40\text{ °C} \leq T_{amb} \leq +60\text{ °C}$; 80395278,

80395279, 80395280; Entity; TYPE 4X; IP67

Entity Parameters: V_{max} (U_i)=30 Volts, I_{max} (I_i)=100 mA, P_i =1 W, C_i =10 nF, L_i =0.5 mH

FM Nonincendive (Code F5)

NI/I/2/ABCD/T4; $-40\text{ °C} \leq T_{amb} \leq +60\text{ °C}$; 80395494; NIFW; TYPE 4X; IP67

NI/I/2/IIC/T4; $-40\text{ °C} \leq T_{amb} \leq +60\text{ °C}$; 80395494; NIFW; TYPE 4X; IP67

S/II, III/1/EFG/T4; $-40\text{ °C} \leq T_{amb} \leq +60\text{ °C}$;

80395494; NIFW; TYPE 4X; P67

Nonincendive Field Wiring Parameters:

V_{max} (U_i)=30 Volts, C_i =10 nF, L_i =0.5 mH

Combination of F1, F2 and F5 (Code F6)**ATEX Flameproof (Code A1)**

KEMA 08ATEX0004

II 1/2 G Ex d IIC T6 $T_{process}=85\text{ °C}$
 $-30\text{ °C} \leq T_{amb} \leq +75\text{ °C}$ IP66/67

II 1/2 G Ex d IIC T5 $T_{process}=100\text{ °C}$
 $-30\text{ °C} \leq T_{amb} \leq +80\text{ °C}$ IP66/67

II 1/2 G Ex d IIC T4 $T_{process}=110\text{ °C}$
 $-30\text{ °C} \leq T_{amb} \leq +80\text{ °C}$ IP66/67

II 2 D Ex tD A21 IP66/67 T85 $T_{process}=85\text{ °C}$
 $-30\text{ °C} \leq T_{amb} \leq +75\text{ °C}$

II 2 D Ex tD A21 IP66/67 T100 $T_{process}=100\text{ °C}$
 $-30\text{ °C} \leq T_{amb} \leq +75\text{ °C}$

II 2 D Ex tD A21 IP66/67 T110 $T_{process}=110\text{ °C}$
 $-30\text{ °C} \leq T_{amb} \leq +75\text{ °C}$

Caution - Use supply wires suitable for 5 °C above surrounding ambient

ATEX Intrinsic Safety (Code A2)

KEMA 07ATEX0200 X

II 1 G Ex ia IIC T4 $T_{process}=105\text{ °C}$
 $-30\text{ °C} \leq T_{amb} \leq +60\text{ °C}$ IP66/67

Electrical Parameters: U_i =30 V, I_i =93 mA, P_i =1 W, C_i =5 nF, L_i =0.5 mH

II 1 D Ex iaD 20 IP66/67 T105 $T_{process}=105\text{ °C}$
 $-30\text{ °C} \leq T_{amb} \leq +60\text{ °C}$

NEPSI Flameproof (Code N1)

Ex d IIC T6 DIP A21 T_A 85 °C $T_{process}=80\text{ °C}$
 $-30\text{ °C} \leq T_{amb} \leq +75\text{ °C}$

Ex d IIC T5 DIP A21 T_A 100 °C $T_{process}=95\text{ °C}$
 $-30\text{ °C} \leq T_{amb} \leq +80\text{ °C}$

Ex d IIC T4 DIP A21 T_A 115 °C $T_{process}=110\text{ °C}$
 $-30\text{ °C} \leq T_{amb} \leq +80\text{ °C}$

ENCLOSURE TYPE IP66/67

NEPSI Intrinsic Safety (Code N2)

Ex ia IIC T4 $T_{process}=105\text{ °C}$
 $-30\text{ °C} \leq T_{amb} \leq +60\text{ °C}$

Enclosure IP66/67

Electrical Parameters: U_i =30 V, I_i =100 mA, P_i =1 W, C_i =13 nF, L_i =0.5 mH

NEPSI Type n (Code N5)

Ex nL IIC T4 $T_{process}=110\text{ °C}$
 $-30\text{ °C} \leq T_{amb} \leq +60\text{ °C}$

Enclosure IP66/67

Electrical Parameters: U_i =30 V, I_i =100 mA, P_i =1 W, C_i =13 nF, L_i =0.5 mH

IECEX Flameproof (Code E1)

Certificate No. IECEX KEM 08.0001
Ga/Gb Ex d IIC T6 $T_{process}=85\text{ °C}$
 $-30\text{ °C} \leq T_{amb} \leq +75\text{ °C}$ IP66/67

Ga/Gb Ex d IIC T5 $T_{process}=100\text{ °C}$
 $-30\text{ °C} \leq T_{amb} \leq +80\text{ °C}$ IP66/67

Ga/Gb Ex d IIC T4 $T_{process}=110\text{ °C}$
 $-30\text{ °C} \leq T_{amb} \leq +80\text{ °C}$ IP66/67

Ex tD A21 IP66/67 T85 $T_{process}=85\text{ °C}$
 $-30\text{ °C} \leq T_{amb} \leq +75\text{ °C}$

Ex tD A21 IP66/67 T100 $T_{process}=100\text{ °C}$
 $-30\text{ °C} \leq T_{amb} \leq +75\text{ °C}$

Ex tD A21 IP66/67 T110 $T_{process}=110\text{ °C}$
 $-30\text{ °C} \leq T_{amb} \leq +75\text{ °C}$

Caution - Use supply wires suitable for 5 °C above surrounding ambient

IECEX Intrinsic Safety (Code E2)

IECEX KEM 07.0058X

Zone 0 Ex ia IIC T4 $T_{process}=105\text{ °C}$
 $-30\text{ °C} \leq T_{amb} \leq +60\text{ °C}$ IP66/67

Electrical Parameters: U_i =30 V, I_i =93 mA, P_i =1 W, C_i =5 nF, L_i =0.5 mH

Ex iaD 20 IP66/67 T105 $T_{process}=105\text{ °C}$
 $-30\text{ °C} \leq T_{amb} \leq +60\text{ °C}$

KOSHA Flameproof (Code K1)

Ex d II C T6 T_{process}=85 °C

-30 °C ≤ T_{amb} ≤ +75 °C

Ex d II C T5 T_{process}=100 °C

-30 °C ≤ T_{amb} ≤ +80 °C

Ex d II C T4 T_{process}=110 °C

-30 °C ≤ T_{amb} ≤ +80 °C

EMC Conformity [☆]

EN 61326-1 (industrial electromagnetic environment)

EN 61326-2-3

FUNCTIONAL SPECIFICATIONS

Type of protection

NEMA 3 and 4X

IEC IP66/67

Measuring span/Setting range/Working pressure range

Model	Measuring Span	Setting Range	Working Pressure Range
GTX 35F	2.5 to 100 kPa {250 to 10160 mmH ₂ O}	-100 to +100 kPa {-10160 to +10160 mmH ₂ O}	Up to flange rating*
GTX 60F	35 to 3500 kPa {0.35 to 35 kgf/cm ² }	-100 to +3500 kPa {-1 to +35 kgf/cm ² }	

Note) For negative pressures, see Figure 1 and Figure 2

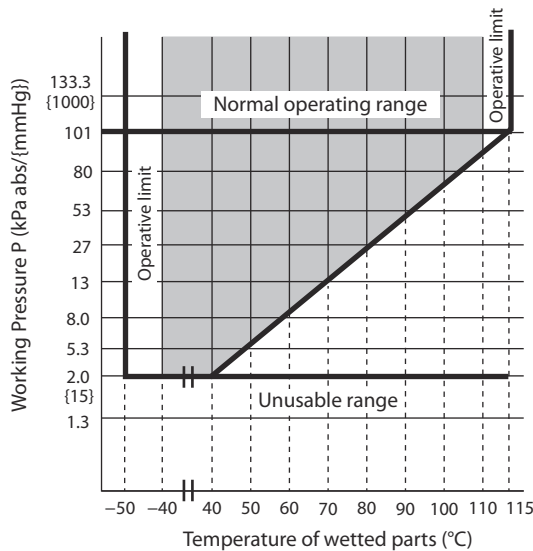

Figure 1. Working pressure and temperature of wetted parts section

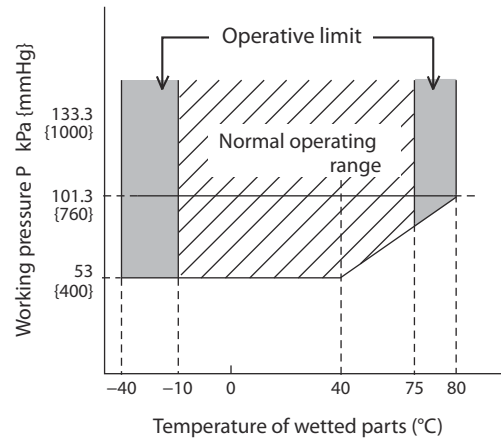

Figure 2. Working pressure and temperature of wetted parts section (for oxygen and chlorine service)

Power Supply [☆]

12.5 to 42 V DC

Limited to 12.5 to 30 V DC for intrinsic safety, Type n, Non-incendive types

Power Supply voltage and load resistance characteristics [☆]

See Figure 3.

Limited to Load resistance: 250 to 1345 Ω for SFN or DE communication. 250 to 600 Ω for HART communication. Power supply voltage: 12.5 to 30 V DC for intrinsic safety, Type n, Nonincendive types

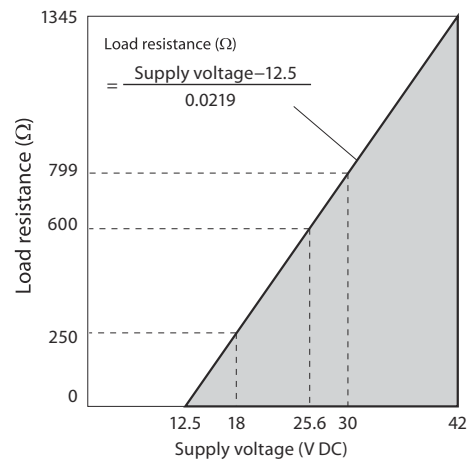

Figure 3. Supply voltage vs. load resistance characteristics

Note) For communication with a communicator, a load resistance of 250 Ω or more is necessary.

Output [☆]

Analog output (4 to 20 mA DC) with DE protocol

Analog output (4 to 20 mA DC) with HART protocol

Digital output (DE protocol)

Output signal [☆]

3.6 to 21.6 mA

3.8 to 20.5 mA (NAMUR NE43 compliant)

Failure Alarm [☆]

Upper: 21.6 mA or more

Lower: 3.6 mA or less

Ambient temperature limit**Normal operating range**

- 30 to +75 °C for general purpose models
- 10 to +75 °C for oxygen and chlorine models
- 25 to +75 °C for models with digital indicators

Operative limits

- 50 to +80 °C for general purpose models
- 40 to +80 °C for oxygen and chlorine models
- 30 to +80 °C for models with digital indicators

Temperature ranges of wetted parts**Normal operating range**

- 40 to +110 °C for general purpose models
- 20 to +75 °C for oxygen and chlorine models

Operative limits

- 50 to +115 °C for general purpose models
- 40 to +80 °C for oxygen and chlorine models

Ambient humidity limits

5 to 100 % RH

Stability against supply voltage change

±0.005 % FS/V

Response time [☆]

Below 150 msec. (when damping time is set to 0 sec.)

Damping time [☆]

Selectable from 0 to 128 sec. (HART)

Selectable from 0 to 32 sec. in ten stages (SFN)

Zero Stability

±0.2 % of URL per 10 year

Lightning protection [☆]

Applicable Standards; IEC 61000-4-5

Peak value of current surge (80/20 μ sec.): 6000 A

Indicator

The digital LCD indicator (optional) shows the output in percentage or in engineering units. Range for engineering unit is from -99999 to 99999 when set at the factory, and from -19999 to 19999 when using the communicator. Specify the following items when placing order with engineering units,

- Pressure range
- Engineering unit of pressure
- Method of display, either linear or square-root.

These data may be set or changed using the communicator.

OPTIONAL SPECIFICATIONS**FEP protective film**

Use FEP protective films when corrosive fluids are used or to avoid metal ions contact.

Working temperature range

0 to 110 °C

Working pressure range

Atmospheric pressure to flange rating (up to JIS10K, ANSI/JPI 150) (Not usable under negative pressure)

Oil free finish

The transmitter is shipped with oil-free wetted parts.

External zero/span adjustment function

The transmitter can be easily adjusted to zero or span in the field.

Indicator must be selected to enable this option.

Fieldbus type does not have span adjustment.

Elbow

This is an adaptor for changing the electrical conduit connection port from the horizontal to the vertical direction, if required by wiring conditions in the field. One or two elbows may be used as needed.

Conformance to SI units

We deliver transmitters set to any SI units as specified.

Safety Transmitter

Select this option to be used as a component of Safety Instrument System (SIS).

AT9000 is complied with IEC61508, certified according to Safety Integrity Level 2 (SIL-2)

This option is not applicable for FOUNDATION Fieldbus type, DE communication type, external zero/span adjustment (option A2), and Alarm output (option Q7).

Alarm Output (contact output)

Contact output is prepared as alarm output when alarm (Output Alarm/Sensor Temp. Alarm) condition is detected. It can be set to or Normally Close.

Contact output type : One open collector (NPN)

Contact rating: 30 V DC max., 30 mA DC max.

Residual voltage at output ON: 3.0 V max.

Operating mode: Normally Open (default)

Normally Close is not recommended.

When this option is selected, CHECK terminals for current check cannot be used.

This option is not applicable for FOUNDATION Fieldbus type, and with intrinsic safety, Type n, Nonincendive types.

Advanced diagnostics [☆]

This option is applicable for FOUNDATION Fieldbus type. Refer to SS2-GTX00Z-0100.

Custom calibration

Calibrate for the specified pressure range at the factory.

PHYSICAL SPECIFICATIONS**Materials****Fill fluid**

Silicone oil for general purpose models

Fluorine oil for oxygen and chlorine models

Center body

316 SST

Transmitter case

Aluminum alloy, CF8M (Equivalent to 316 SST)

Meter body cover flange

SCS14A (Equivalent to 316 SST) or 316 SST

Bolts and nuts (for fastening meter body cover)

Carbon steel (SNB7), 304 SST, 630 SST

O-ring

NBR

For Wetted parts**Adapter flange (option)**

SCS14A (equivalent to 316 SST)

Center body

316 SST (316L SST for diaphragm only), ASTM B575 (Hastelloy C-276 equivalent), Tantalum, 316L SST

Vents and plugs

316 SST

Gaskets

PTFE

Flange materials

304 SST, 316 SST, 316L SST

Paint

Standard: Baked acrylic paint

Corrosion-proof: Baked urethane paint

Color

Housing: Silver N-8.2

Cap: azbil bordeaux 2.5R 2.25/5

Weight

Approx. 5.9 kg (in case of ANSI 150# - 1-1/2 inches flange)

INSTALLATION**Electrical connection**

1/2 NPT internal thread, M20 internal thread.

Grounding

Resistance 100 Ω max.

Mounting

Direct mounting on the process side

Process connection**Measured pressure (liquid side)****Flush diaphragm**

JIS 10K, 20K, 30K and 63K: 40, 50 and 80 mm (RF) equivalents

ANSI/JPI 150, 300 and 600: 1.5, 2, 3 inches (RF) equivalents

Extended diaphragm

JIS 10K, 20K and 30K: 50, 80 and 100 mm (RF) equivalents

ANSI/JPI 150, 300 and 600: 2, 3 inches (RF) equivalents

ANSI/JPI 150 and 300: 4 inches (RF) equivalents

Flange standard

JIS; JIS B 2220 (2004)

ANSI; ANSI B 16.5 (1988)

JPI; JPI-7S-15-93

Standard pressure side

Rc1/2, 1/2 NPT internal thread, Rc1/4, 1/4 NPT internal thread, atmospheric disconnection hole.

TRANSMITTER HANDLING NOTES

To get the most from the performance this transmitter can offer, please use it properly noting the points mentioned below. Before using it, please read the Instruction Manual.

Transmitter installation notes**⚠ WARNING**

- When installing the transmitter, ensure that gaskets do not protrude from connecting points into the process (such as adapter flange connection points and connecting pipes and flanges). Failure to do so may cause a leak of process fluid, resulting in harm from burns, etc. In addition, if the process fluid contains toxic substances, take safety measures such as wearing goggles and a mask to prevent contact with the skin and eyes and to prevent inhalation.
- Use the transmitter within the operating ranges stated in the specifications (for explosion-proofing, pressure rating, temperature, humidity, voltage, vibration, shock, mounting direction, atmosphere, etc.). Using the transmitter outside the operating conditions may cause device failure or fire, resulting in a harmful physical risk of burning or the like.
- When performing wiring work in explosion-proof areas, follow the work method specified in the explosion-proof guidelines.

⚠ CAUTION

- After installation, do not use the transmitter as a foothold or put your weight on it. Doing so may cause damage.
- Be careful not to hit the glass indicator with tools etc. This could break the glass and cause injury.
- The transmitter is heavy. Wear safety shoes and take care when installing it.
- Impact to transmitter can damage sensor module.

Wiring notes**⚠ WARNING**

- To avoid shocks, do not perform electrical wiring work with wet hands or with live wires.

⚠ CAUTION

- Do wiring work properly in conformance with the specifications. Wiring mistakes may result in malfunction or irreparable damage to the instrument.
- Use a power supply that conforms to the specifications. Use of an improper power supply may result in malfunction or irreparable damage to the instrument.
- Use a power supply with overcurrent protection for this instrument.

Handling precautions for HART specification devices

- If you need to operate with a secondary host (HART communicator, etc.), set the communication interval of the primary host (DCS, device management system) to 8 seconds or more, or suspend communication from the primary host. If the primary host repeats HART communication within 8 seconds, the request from the secondary host may not be received (communication may not be possible).
- If electrical noise in the environment prevents HART communications with the host, take countermeasures such as separating the signal cables from the source of the noise, improving the grounding, changing to shielded signal cables, etc. Even if noise interferes with HART communications, the 4–20 mA analog signal will be unaffected and can be used for control.
- If this product is being operated in multidrop mode, there is a limit to the number of devices that can be used. If you are using multidrop mode, please consult with us.

PERFORMANCE SPECIFICATIONS

Max working pressure

Note) 1. Max. working pressure depends on flange rating, flange materials and operating temperature. Please refer to the following data. Operating range of temperature depends on specification of transmitters.

2. In case of flange type (GTX60F), max working pressure depends on the smaller value of either 1.5 MPa or following data.

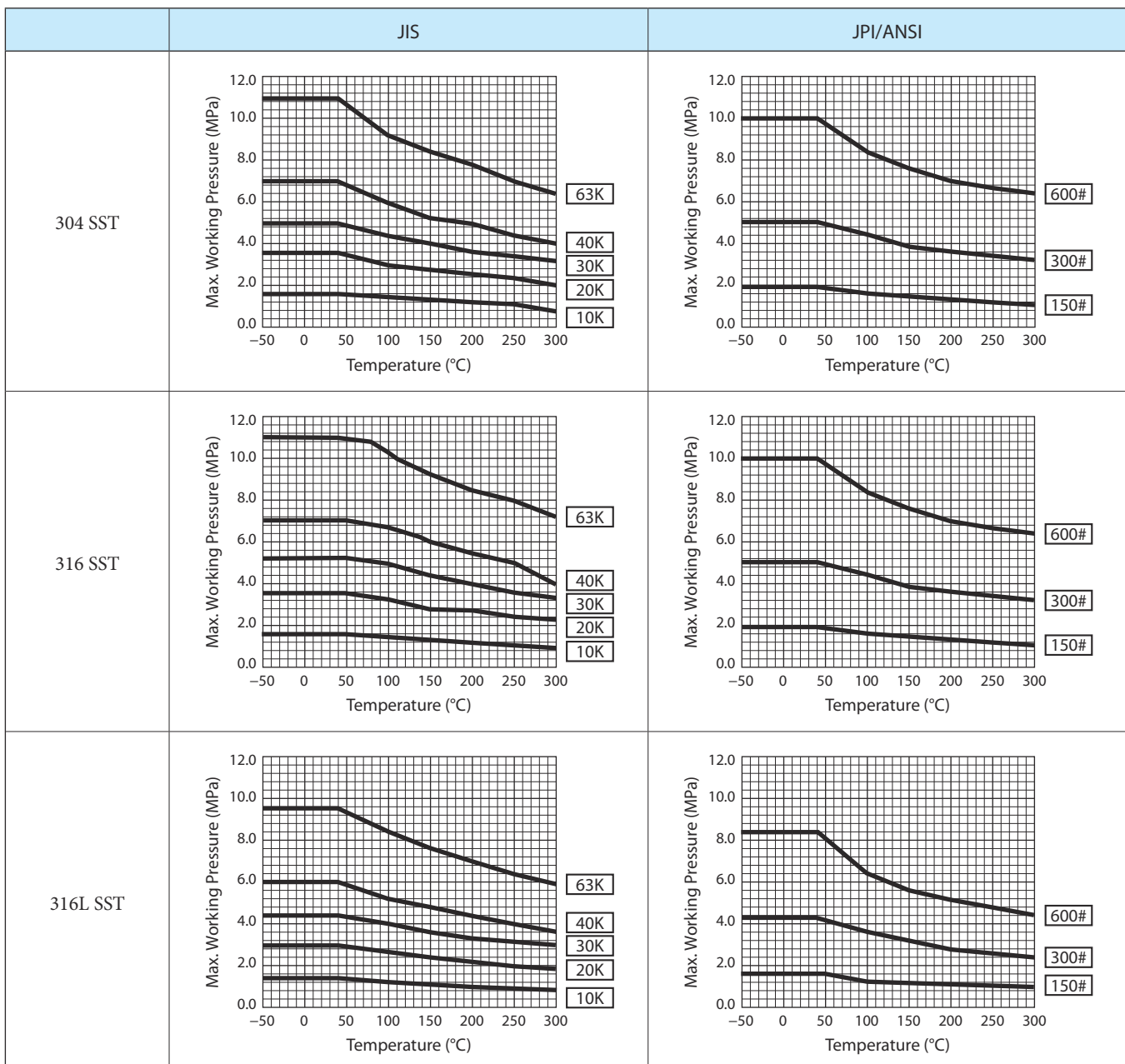

Reference accuracy

Shown for each item are the percentage ratio for x (kPa), which is the greatest value of either the upper range value (URV)*¹, the lower range value (LRV)*² or the span.

Model GTX35F

Material of Wetted Parts at Flange Side: 316 SST (Diaphragm; 316L SST), 316L SST,

Material of Wetted parts at reference side: 316 SST (Diaphragm; 316L SST)

Reference accuracy * ³	Linear output:	$\pm 0.2 \%$	(For $x \geq 12.5$ kPa {1250 mmH ₂ O})
		$\pm \left(0.05 + 0.15 \times \frac{12.5}{x} \right) \%$	(For $x < 12.5$ kPa {1250 mmH ₂ O})
Ambient Temperature effect (Shift from the set range) Change of 30 °C (Range from -5 to +55 °C)	Combined shift: (including zero and span shifts)	$\pm 1.45 \%$	(For $x \geq 12.5$ kPa {1250 mmH ₂ O})
		$\pm \left(0.35 + 1.1 \times \frac{12.5}{x} \right) \%$	(For $x < 12.5$ kPa {1250 mmH ₂ O})
Static pressure effect (Shift in respect to setting range) Change of 7 MPa {70 kgf/cm ² }	Zero shift:	$\pm \left(0.03 + 0.64 \times \frac{25}{x} \right) \%$	
	Combined shift: (including zero and span shifts)	$\pm 0.97 \%$	(For $x \geq 25$ kPa {2500 mmH ₂ O})
		$\pm \left(0.03 + 0.94 \times \frac{25}{x} \right) \%$	(For $x < 25$ kPa {2500 mmH ₂ O})

Model GTX35F (For option "M5", 0.1 mm thickness diaphragm)

Material of Wetted Parts at Flange Side: 316 SST (Diaphragm; 316L SST), 316L SST,

Material of Wetted parts at reference side: 316 SST (Diaphragm; 316L SST)

Reference accuracy * ³	Linear output:	$\pm 0.8 \%$	(For $x \geq 12.5$ kPa {1250 mmH ₂ O})
		$\pm \left(0.15 + 0.3 \times \frac{12.5}{x} \right) \%$	(For $x < 12.5$ kPa {1250 mmH ₂ O})
Ambient Temperature effect (Shift from the set range) Change of 30 °C (Range from -5 to +55 °C)	Combined shift: (including zero and span shifts)	$\pm \left(0.6 + 5.4 \times \frac{25}{x} \right) \%$	
Static pressure effect (Shift in respect to setting range) Change of 7 MPa {70 kgf/cm ² }	Zero shift:	$\pm \left(0.64 + 2.64 \times \frac{25}{x} \right) \%$	
	Combined shift: (including zero and span shifts)	$\pm \left(1.17 + 2.0 \times \frac{25}{x} \right) \%$	(For $x \geq 25$ kPa {2500 mmH ₂ O})
		$\pm \left(0.23 + 2.94 \times \frac{25}{x} \right) \%$	(For $x < 25$ kPa {2500 mmH ₂ O})

Model GTX35F

Material of Wetted Parts at Flange Side: ASTM B575 (Hastelloy C-276 equivalent), Tantalum,

Material of Wetted parts at reference side: 316 SST (Diaphragm; 316L SST)

Reference accuracy * ³	Linear output:	$\pm 0.4 \%$	(For $x \geq 12.5$ kPa {1250 mmH ₂ O})
		$\pm \left(0.25 + 0.15 \times \frac{12.5}{x} \right) \%$	(For $x < 12.5$ kPa {1250 mmH ₂ O})
Ambient Temperature effect (Shift from the set range) Change of 30 °C (Range from -5 to +55 °C)	Combined shift: (including zero and span shifts)	$\pm \left(0.6 + 2.4 \times \frac{25}{x} \right) \%$	
Static pressure effect (Shift in respect to setting range) Change of 7 MPa {70 kgf/cm ² }	Zero shift:	$\pm \left(0.03 + 1.64 \times \frac{25}{x} \right) \%$	
	Combined shift: (including zero and span shifts)	$\pm \left(1.07 + 1.0 \times \frac{25}{x} \right) \%$	(For $x \geq 25$ kPa {2500 mmH ₂ O})
		$\pm \left(0.13 + 1.94 \times \frac{25}{x} \right) \%$	(For $x < 25$ kPa {2500 mmH ₂ O})

*1. URV denotes the process value for 100 % (20 mA DC) output.

*2. LRV denotes the process value for 0 % (4 mA DC) output.

*3. Reference accuracy at calibrated condition.

Model GTX60F

Material of Wetted Parts at Flange Side: 316 SST (Diaphragm; 316L SST), 316L SST,

Material of Wetted parts at reference side: 316 SST (Diaphragm; 316L SST)

Reference accuracy *3 *4	Linear output:	$\pm 0.15 \%$	(For $x \geq 350$ kPa {3.5 kgf/cm ² })
		$\pm \left(0.05 + 0.1 \times \frac{350}{x} \right) \%$	(For $x < 350$ kPa {3.5 kgf/cm ² })
Ambient Temperature effect (Shift from the set range) Change of 30 °C *4 (Range from -5 to +55 °C)	Combined shift: (including zero and span shifts)	$\pm 0.75 \%$	(For $x \geq 350$ kPa {3.5 kgf/cm ² })
		$\pm \left(0.35 + 0.4 \times \frac{350}{x} \right) \%$	(For $x < 350$ kPa {3.5 kgf/cm ² })
Static pressure effect (Shift in respect to setting range)*4 Change of 7 MPa {70 kgf/cm ² }	Zero shift:	$\pm \left(0.03 + 7.5 \times \frac{350}{x} \right) \%$	
	Combined shift: (including zero and span shifts)	$\pm 9.00 \%$	(For $x \geq 350$ kPa {3.5 kgf/cm ² })
		$\pm \left(1.5 + 7.5 \times \frac{350}{x} \right) \%$	(For $x < 350$ kPa {3.5 kgf/cm ² })

Model GTX60F (For option "M5", 0.1 mm thickness diaphragm)

Material of Wetted Parts at Flange Side: 316 SST (Diaphragm; 316L SST), 316L SST,

Material of Wetted parts at reference side: 316 SST (Diaphragm; 316L SST)

Reference accuracy *3 *4	Linear output:	$\pm 0.6 \%$	(For $x \geq 350$ kPa {3.5 kgf/cm ² })
		$\pm \left(0.3 + 0.3 \times \frac{350}{x} \right) \%$	(For $x < 350$ kPa {3.5 kgf/cm ² })
Ambient Temperature effect (Shift from the set range) Change of 30 °C *4 (Range from -5 to +55 °C)	Combined shift: (including zero and span shifts)	$\pm \left(0.35 + 2.6 \times \frac{350}{x} \right) \%$	
Static pressure effect (Shift in respect to setting range) *4	Zero shift:	$\pm \left(0.03 + 9.5 \times \frac{350}{x} \right) \%$	
	Combined shift: (including zero and span shifts)	$\pm 9.0 \%$	(For $x \geq 350$ kPa {3.5 kgf/cm ² })
		$\pm \left(1.5 + 7.5 \times \frac{350}{x} \right) \%$	(For $x < 350$ kPa {3.5 kgf/cm ² })

Model GTX60F

Material of Wetted Parts at Flange Side: ASTM B575 (Hastelloy C-276 equivalent), Tantalum,

Material of Wetted parts at reference side: 316 SST (Diaphragm; 316L SST)

Reference accuracy *3 *4	Linear output:	$\pm 0.3 \%$	(For $x \geq 350$ kPa {3.5 kgf/cm ² })
		$\pm \left(0.15 + 0.15 \times \frac{350}{x} \right) \%$	(For $x < 350$ kPa {3.5 kgf/cm ² })
Ambient Temperature effect (Shift from the set range) Change of 30 °C *4 (Range from -5 to +55 °C)	Combined shift: (including zero and span shifts)	$\pm \left(0.35 + 0.65 \times \frac{350}{x} \right) \%$	
Static pressure effect (Shift in respect to setting range)*4 Change of 7 MPa {70 kgf/cm ² }	Zero shift:	$\pm \left(0.03 + 8.5 \times \frac{350}{x} \right) \%$	
	Combined shift: (including zero and span shifts)	$\pm 9.0 \%$	(For $x \geq 350$ kPa {3.5 kgf/cm ² })
		$\pm \left(1.5 + 7.5 \times \frac{350}{x} \right) \%$	(For $x < 350$ kPa {3.5 kgf/cm ² })

*3. Reference accuracy at calibrated condition.

*4. Within a range of $URV \geq 0$ and $LRV \geq 0$.

MODEL SELECTION**Model GTX35F (Flange type for standard differential pressure)****Model GTX60F (Flange type for high differential pressure)**

Model No.: GTX_ _F - Selection I (I II III IV V VI VII VIII IX X XI) - Selection II (I II III IV V VI) - Option

Basic Model No.

Measuring span	2.5 to 100 kPa (250 to 10,160 mmH ₂ O)	GTX35F	Flush flange type 3 inches (80 mm)
	35 to 3500 kPa (0.35 to 35 kgf/cm ²)	GTX60F	

Selection I

I	Output	4 to 20 mA (SFN Communication)		A	
		4 to 20 mA (HART Communication)		B	
		FOUNDATION Fieldbus communication		C	
		Digital output (DE communication) *5		D	
II	Fill fluid	Regular type (Silicone oil)		A	
		For oxygen service (Fluorine oil)		H	
		For chlorine service (Fluorine oil) *1		J	
III	Material (Meterbody cover, Vent/Drain plugs)	Meterbody cover	Vent/Drain plugs	A	
		SCS14A	316 SST		
IV	Material (centerbody)	Reference side	Wetted part of flange side		
		316 SST	316 SST (Diaphragm: 316L SST)		A
		316 SST	ASTM B575		B
		316 SST	Tantalum *1		C
		316 SST	316L SST		D
V	Process connections of reference side	Rc 1/2, with adapter flange *4		A	
		Rc 1/4, with adapter flange *4		B	
		Rc 1/4, without adapter flange *4		C	
		1/2 NPT internal thread, with adapter flange *4		D	
		1/4 NPT internal thread, with adapter flange *4		E	
		1/4 NPT internal thread, without adapter flange *4		F	
		Open to atmosphere *3		H	
VI	Process installation of reference side	No connection *3		X	
		Vertical piping, top connection		A	
		Vertical piping, bottom connection		B	
VII	Flange rating	ANSI150		A1	
		ANSI300		A2	
		ANSI600		A3	
		JIS10K		J1	
		JIS20K		J3	
		JIS30K		J4	
		JIS63K		J6	
		JPI150		P1	
		JPI300		P2	
		JPI600		P3	
VIII	Flange size	3 in./80 A		F	
IX	Flange type	Flush type		A	
X	Flange material/bolt and nut material	Flange	Bolt and nut		
		304 SST	304 SST		A
		304 SST	Carbon steel		D
		316 SST	304 SST		E
		316 SST	Carbon steel		H
		316L SST	304 SST		J
		316L SST	Carbon steel		M
XI	Gasket face finish	None, Standard JISRa3.2 (12.5S)		A	

Model No.: GTX_ _F - Selection I (I II III IV V VI VII VIII IX X XI) - **Selection II (I II III IV V VI)** - Option

Selection II

			—	
I	Electrical connection	1/2 NPT, Watertight	A	
		M20, Watertight *2	B	
II	Explosion proof [☆] *8	None		XX
		FM Explosionproof for Division system/Flameproof for Zone system		F1
		FM Intrinsic safety		F2
		FM Nonincendive		F5
		Combination of code F1, F2, and F5		F6
		ATEX Flameproof		A1
		ATEX Intrinsic safety		A2
		IECEX Flameproof		E1
		IECEX Intrinsic safety		E2
		NEPSI Flameproof		N1
		NEPSI Intrinsic safety		N2
		NEPSI Type n		N5
		KOSHA Flameproof *6		K1
III	Built-in indicating smart meter	None		X
		With indicator *9	A	
IV	Paint *7	Standard		X
		None (316 stainless steel housing)		E
		Corrosion-proof (Urethane)		H
V	Burnout feature	UP Scale		A
		DOWN scale		B
		None (for FOUNDATION Fieldbus) *10		X
VI	Mounting Bracket	None		X

*1. In case code J is selected, code C “Tantalum”, wetted part material of flange side should be selected.

*2. Not applicable for the combination with code F1, F6 “FM Explosion proof” of Explosion proof.

*3. In case code H is selected, code X “No connection” of process installation of reference side should be selected.

*4. Not applicable for the combination with code X “No connection” of Process installation of reference side.

*5. Not applicable for the combination with code A2 “With external Zero/Span adjustment”, Q1 “Safety Transmitter”, and Q2 “NAMUR NE43 Compliant Output signal limits” of Option.

*6. Not applicable for the combination with code E of Paint.

*7. In case code X or H is selected, the material of transmitter case is aluminum alloy.

*8. For FOUNDATION Fieldbus type. Refer to SS2-GTX00Z-0100.

*9. In case the code C “FOUNDATION Fieldbus communication” of output is selected, code A2 of Option code should be selected.

*10. Not applicable for the combination with code A “4 to 20 mA (SFN Communication)”, B “4 to 20 mA (HART Communication)”, and D “Digital output (DE communication)” of output.

Model GTX35F (Flange type for standard differential pressure)
Model GTX60F (Flange type for high differential pressure)

Model No.: GTX_ _F - Selection I (I II III IV V VI VII VIII IX X XI) - Selection II (I II III IV V VI) - Option

Basic Model No.

Measuring span	2.5 to 100 kPa (250 to 10,160 mmH ₂ O)	GTX35F	Extended flange type 4 inches (100 mm)
	35 to 3500 kPa (0.35 to 35 kgf/cm ²)	GTX60F	

Selection I

I	Output	4 to 20 mA (SFN Communication)		A	
		4 to 20 mA (HART Communication)		B	
		FOUNDATION Fieldbus communication		C	
		Digital output (DE communication) *4		D	
II	Fill fluid	Regular type (Silicone oil)		A	
		For oxygen service (Fluorine oil)		H	
III	Material (Meterbody cover, Vent/Drain plugs)	Meterbody cover	Vent/Drain plugs		
		SCS14A	316 SST	A	
IV	Material (centerbody)	Reference side	Wetted part of flange side		
		316 SST	316 SST (Diaphragm: 316L SST)	A	
		316 SST	316L SST	D	
V	Process connections of reference side	Rc 1/2, with adapter flange *3		A	
		Rc 1/4, with adapter flange *3		B	
		Rc 1/4, without adapter flange *3		C	
		1/2 NPT internal thread, with adapter flange *3		D	
		1/4 NPT internal thread, with adapter flange *3		E	
		1/4 NPT internal thread, without adapter flange *3		F	
VI	Process installation of reference side	No connection *2		X	
		Vertical piping, top connection		A	
		Vertical piping, bottom connection		B	
VII	Flange rating	ANSI150		A1	
		ANSI300		A2	
		JIS10K		J1	
		JIS20K		J3	
		JIS30K *5		J4	
		JPI150		P1	
		JPI300		P2	
VIII	Flange size	4 in./100 A		G	
IX	Flange type	Extended Length 50 mm		B	
		Extended Length 100 mm		C	
		Extended Length 150 mm		D	
		Extended Length 200 mm		E	
		Extended Length 250 mm		F	
		Extended Length 300 mm		G	
X	Flange material/bolt and nut material	Flange	Bolt and nut		
		304 SST	304 SST		A
		304 SST	Carbon steel		D
		316 SST	304 SST		E
		316 SST	Carbon steel		H
		316L SST	304 SST		J
XI	Gasket face finish	None, Standard JISRa3.2 (12.5S)		A	

Model No.: GTX_ _F - Selection I (I II III IV V VI VII VIII IX X XI) - Selection II (I II III IV V VI) - Option

Selection II

		—	
I	Electrical connection	1/2 NPT, Watertight	A
		M20, Watertight *2	B
II	Explosion proof [☆] *8	None	XX
		FM Explosionproof for Division system/Flameproof for Zone system	F1
		FM Intrinsic safety	F2
		FM Nonincendive	F5
		Combination of code F1, F2, and F5	F6
		ATEX Flameproof	A1
		ATEX Intrinsic safety	A2
		IECEx Flameproof	E1
		IECEx Intrinsic safety	E2
		NEPSI Flameproof	N1
		NEPSI Intrinsic safety	N2
		NEPSI Type n	N5
		KOSHA Flameproof *6	K1
III	Built-in indicating smart meter	None	X
		With indicator *9	A
IV	Paint *7	Standard	X
		None (316 stainless steel housing)	E
		Corrosion-proof (Urethane)	H
V	Burnout feature	UP Scale	A
		DOWN scale	B
		None (for FOUNDATION Fieldbus) *10	X
VI	Mounting Bracket	None	X

*1. Not applicable for the combination with code F1, F6 “FM Explosion proof” of Explosion proof.

*2. In case code M is selected, code X “No connection” of process installation of reference side should be selected.

*3. Not applicable for the combination with code X “No connection” of Process installation of reference side.

*4. Not applicable for the combination with code A2 “With external Zero/Span adjustment”, Q1 “Safety Transmitter”, and Q2 “NAMUR NE43 Compliant Output signal limits” of Option.

*5. In case flange rating “JIS30K” and wetted part of flange side “316L SST”, not applicable for Extended Length: 300 mm.

*6. Not applicable for the combination with code E of Paint.

*7. In case code X or H is selected, the material of transmitter case is aluminum alloy.

*8. For FOUNDATION Fieldbus type. Refer to SS2-GTX00Z-0100.

*9. In case the code C “FOUNDATION Fieldbus communication” of output is selected, code A2 of Option code should be selected.

*10. Not applicable for the combination with code A “4 to 20 mA (SFN Communication)”, B “4 to 20 mA (HART Communication)”, and D “Digital output (DE communication)” of output.

Model GTX35F (Flange type for standard differential pressure)
Model GTX60F (Flange type for high differential pressure)

Model No.: GTX_ _F - Selection I (I II III IV V VI VII VIII IX X XI) - Selection II (I II III IV V VI) - Option

Basic Model No.

Measuring span	2.5 to 100 kPa (250 to 10,160 mmH ₂ O)	GTX35F	Flush flange type 2 inches (50 mm), 1 1/2 inches (40 mm)
	35 to 3500 kPa (0.35 to 35 kgf/cm ²)	GTX60F	

Selection I

I	Output	4 to 20 mA (SFN Communication)		A	
		4 to 20 mA (HART Communication)		B	
		FOUNDATION Fieldbus communication		C	
		Digital output (DE communication) *7		D	
II	Fill fluid	Regular type (Silicone oil)		A	
		For oxygen service (Fluorine oil)		H	
		For chlorine service (Fluorine oil) *1		J	
III	Material (Meterbody cover, Vent/Drain plugs)	Meterbody cover	Vent/Drain plugs		
		SCS14A	316 SST	A	
IV	Material (centerbody)	Reference side	Wetted part of flange side		
		316 SST	316 SST (Diaphragm: 316L SST)	A	
		316 SST	ASTM B575 (Equivalent to Hastelloy C-276)	B	
		316 SST	Tantalum *1	C	
		316 SST	316L SST	D	
V	Process connections of reference side	Rc 1/2, with adapter flange *6		A	
		Rc 1/4, with adapter flange *6		B	
		Rc 1/4, without adapter flange *6		C	
		1/2 NPT internal thread, with adapter flange *6		D	
		1/4 NPT internal thread, with adapter flange *6		E	
		1/4 NPT internal thread, without adapter flange *6		F	
		Open to atmosphere *5		H	
VI	Process installation of reference side	No connection *6		X	
		Vertical piping, top connection		A	
		Vertical piping, bottom connection		B	
VII	Flange rating	ANSI150		A1	
		ANSI300		A2	
		ANSI600		A3	
		JIS10K		J1	
		JIS20K		J3	
		JIS30K		J4	
		JIS63K		J6	
		JPI150		P1	
		JPI300		P2	
		JPI600		P3	
VIII	Flange size	1 1/2 in./40 A *2 *3		D	
		2 in./50 A		E	
IX	Flange type	Flush type		A	
X	Flange material/bolt and nut material	Flange	Bolt and nut		
		304 SST	304 SST		A
		304 SST	Carbon steel		D
		316 SST	304 SST		E
		316 SST	Carbon steel		H
		316L SST	304 SST		J
		316L SST	Carbon steel		M
XI	Gasket face finish	None, Standard JISR3.2 (12.5S)		A	

Model No.: GTX_ _F - Selection I (I II III IV V VI VII VIII IX X XI) - Selection II (I II III IV V VI) - Option

Selection II

		—	
I	Electrical connection	1/2 NPT, Watertight	A
		M20, Watertight *4	B
II	Explosion proof [☆] *10	None	XX
		FM Explosionproof for Division system/Flameproof for Zone system	F1
		FM Intrinsic safety	F2
		FM Nonincendive	F5
		Combination of code F1, F2, and F5	F6
		ATEX Flameproof	A1
		ATEX Intrinsic safety	A2
		IECEX Flameproof	E1
		IECEX Intrinsic safety	E2
		NEPSI Flameproof	N1
		NEPSI Intrinsic safety	N2
		NEPSI Type n	N5
		KOSHA Flameproof *8	K1
III	Built-in indicating smart meter	None	X
		With indicator *11	A
IV	Paint *9	Standard	X
		None (316 stainless steel housing)	E
		Corrosion-proof (Urethane)	H
V	Burnout feature	UP Scale	A
		DOWN scale	B
		None (for FOUNDATION Fieldbus) *12	X
VI	Mounting Bracket	None	X

*1. In case code J is selected, code C “Tantalum”, wetted part material of flange side should be selected.

*2. Not applicable for the combination with code J “For chlorine service” of Fill Fluid.

*3. Not applicable for the combination with code C “Tantalum” of Material of wetted part of flange side.

*4. Not applicable for the combination with code F1, F6 “FM Explosion proof” of Explosion proof.

*5. In case code M is selected, code X “No connection” of process installation of reference side should be selected.

*6. Not applicable for the combination with code X “No connection” of Process installation of reference side.

*7. Not applicable for the combination with code A2 “With external Zero/Span adjustment”, Q1 “Safety Transmitter”, and Q2 “NAMUR NE43 Compliant Output signal limits” of Option.

*8. Not applicable for the combination with code E of Paint.

*9. In case code X or H is selected, the material of transmitter case is aluminum alloy.

*10. For FOUNDATION Fieldbus type. Refer to SS2-GTX00Z-0100.

*11. In case the code C “FOUNDATION Fieldbus communication” of output is selected, code A2 of Option code should be selected.

*12. Not applicable for the combination with code A “4 to 20 mA (SFN Communication)”, B “4 to 20 mA (HART Communication)”, and D “Digital output (DE communication)” of output.

Model GTX35F (Flange type for standard differential pressure)
Model GTX60F (Flange type for high differential pressure)

Model No.: GTX_ _F - Selection I (I II III IV V VI VII VIII IX X XI) - Selection II (I II III IV V VI) - Option

Basic Model No.

Measuring span	2.5 to 100 kPa (250 to 10,160 mmH ₂ O)	GTX35F	Extended flange type 3 inches (80 mm), 2 inches (50 mm)
	35 to 3500 kPa (0.35 to 35 kgf/cm ²)	GTX60F	

Selection I

I	Output	4 to 20 mA (SFN Communication)		A	
		4 to 20 mA (HART Communication)		B	
		FOUNDATION Fieldbus communication		C	
		Digital output (DE communication) *4		D	
II	Fill fluid	Regular type (Silicone oil)		A	
		For oxygen service (Fluorine oil)		H	
III	Material (Meterbody cover, Vent/Drain plugs)	Meterbody cover	Vent/Drain plugs		
		SCS14A	316 SST	A	
IV	Material (centerbody)	Reference side	Wetted part of flange side		
		316 SST	316 SST (Diaphragm: 316L SST)	A	
		316 SST	316L SST	D	
V	Process connections of reference side	Rc 1/2, with adapter flange		A	
		Rc 1/4, with adapter flange		B	
		Rc 1/4, without adapter flange		C	
		1/2 NPT internal thread, with adapter flange		D	
		1/4 NPT internal thread, with adapter flange		E	
		1/4 NPT internal thread, without adapter flange		F	
		Open to atmosphere *2		H	
VI	Process installation of reference side	No connection *2 *3		X	
		Vertical piping, top connection		A	
		Vertical piping, bottom connection		B	
VII	Flange rating	ANSI150		A1	
		ANSI300		A2	
		JIS10K		J1	
		JIS20K		J3	
		JIS30K		J4	
		JPI150		P1	
		JPI300		P2	
VIII	Flange size	2 in./50 A		E	
		3 in./80 A		F	
IX	Flange type	Extended Length 50 mm		B	
		Extended Length 100 mm		C	
		Extended Length 150 mm		D	
X	Flange material/bolt and nut material	Flange	Bolt and nut		
		304 SST	304 SST		A
		304 SST	Carbon steel		D
		316 SST	304 SST		E
		316 SST	Carbon steel		H
		316L SST	304 SST		J
316L SST	Carbon steel		M		
XI	Gasket face finish	None, Standard JISRa3.2 (12.5S)		A	

Model No.: GTX_ _F - Selection I (I II III IV V VI VII VIII IX X XI) - Selection II (I II III IV V VI) - Option

Selection II

			-	
I	Electrical connection	1/2 NPT, Watertight	A	
		M20, Watertight *1	B	
II	Explosion proof [☆] *7	None		XX
		FM Explosionproof for Division system/Flameproof for Zone system		F1
		FM Intrinsic safety		F2
		FM Nonincendive		F5
		Combination of code F1, F2, and F5		F6
		ATEX Flameproof		A1
		ATEX Intrinsic safety		A2
		IECEX Flameproof		E1
		IECEX Intrinsic safety		E2
		NEPSI Flameproof		N1
		NEPSI Intrinsic safety		N2
		NEPSI Type n		N5
		KOSHA Flameproof *5		K1
III	Built-in indicating smart meter	None	X	
		With indicator *8	A	
IV	Paint *6	Standard		X
		None (316 stainless steel housing)		E
		Corrosion-proof (Urethane)		H
V	Burnout feature	UP Scale		A
		DOWN scale		B
		None (for FOUNDATION Fieldbus) *9		X
VI	Mounting Bracket	None		X

*1. Not applicable for the combination with code F1, F6 “FM Explosion proof” of Explosion proof.

*2. In case code H is selected, code X “No connection” of process installation of reference side should be selected.

*3. Not applicable for the combination with code X “No connection” of Process installation of reference side.

*4. Not applicable for the combination with code A2 “With external Zero/Span adjustment”, Q1 “Safety Transmitter”, and Q2 “NAMUR NE43 Compliant Output signal limits” of Option.

*5. Not applicable for the combination with code E of Paint.

*6. In case code X or H is selected, the material of transmitter case is aluminum alloy.

*7. For FOUNDATION Fieldbus type. Refer to SS2-GTX00Z-0100.

*8. In case the code C “FOUNDATION Fieldbus communication” of output is selected, code A2 of Option code should be selected.

*9. Not applicable for the combination with code A “4 to 20 mA (SFN Communication)”, B “4 to 20 mA (HART Communication)”, and D “Digital output (DE communication)” of output.

Model No.: GTX__F - Selection I (I II III IV V VI VII VIII IX X XI) - Selection II (I II III IV V VI) - Option

Option

	No options	XX
	With external Zero/Span adjustment (With external ZERO adjustment only for FOUNDATION Fieldbus)*8 *9	A2
	One elbow (left) *3 *4 *7	G1
	One elbow (right) *3 *4 *7	G2
	2 elbows *3 *5 *7	G3
	Oil and water free finish	K1
	Oil free finish *1	K3
	Au Plating Diaphragm	L1
	0.1 mm thickness diaphragm *16 *17	M5
	FEP protective film *18	N1
	316 SST (Parts in contact with atmosphere) *11 *12 *13	P8
	Safety Transmitter *2 *9 *14	Q1
	NAMUR NE43 Compliant Output Signal Limits: 3.8 to 20.5 mA (Output 21.6 mA/selected upper limit, 3.6 mA/selected lower limit) *9 *14	Q2
	Alarm Output (contact output) *10 *14	Q7
	Advanced diagnostics *15	Q8
	Custom calibration	R1
	Test report	T1
	Mill certificate	T2
	Traceability certificate	T4
	NACE certificate *6	T5
	Non SI Unit	W1

*1. No need to select when Fill Fluid code H, or J is selected.

*2. Not applicable for the combination with code A2, or Q7 of Option.

*3. Not applicable for the combination with code A, or B of Process installation.

*4. Not applicable for the combination with code F1, F6 of Explosion proof.

*5. Not applicable for any Explosion proof. Please select code XX "None" of Explosion proof.

*6. Applicable for "ASTM B575", code B of Material (center body).

*7. Not applicable for the combination with code B "M20, Watertight" electrical connection.

*8. Not applicable for the combination with code X "None" of Indicator. Please select "With indicator".

*9. Not applicable for the combination with code D "Digital output (DE communication)" of output.

*10. Not applicable for the combination with code F2, F5, F6, N2, N5, E2, and A2 of Explosion proof.

*11. In case code P8 is selected, code D of Bolt/nut should be selected.

*12. In case code P8 is selected, code E of Paint should be selected.

*13. In case code P8 is selected, code X or 2 of Mounting bracket should be selected.

*14. Not applicable for the combination with code C "Digital output (FOUNDATION Fieldbus communication)" of output.

*15. Not applicable for the combination with code A "4 to 20 mA (SFN Communication)", B "4 to 20 mA (HART Communication)", and D "Digital output (DE communication)" of output.

*16. 0.1 mm thickness diaphragm option is only available for Material of Wetted parts: "316 SST" and "316L SST".

*17. 0.1 mm thickness diaphragm option is only available for 4 inches Extended Flange or 3 inches Flush Flange.

*18. Not applicable for the combination with Extended Flange Type.

DIMENSIONS

Model GTX35F/60F

Unit: mm

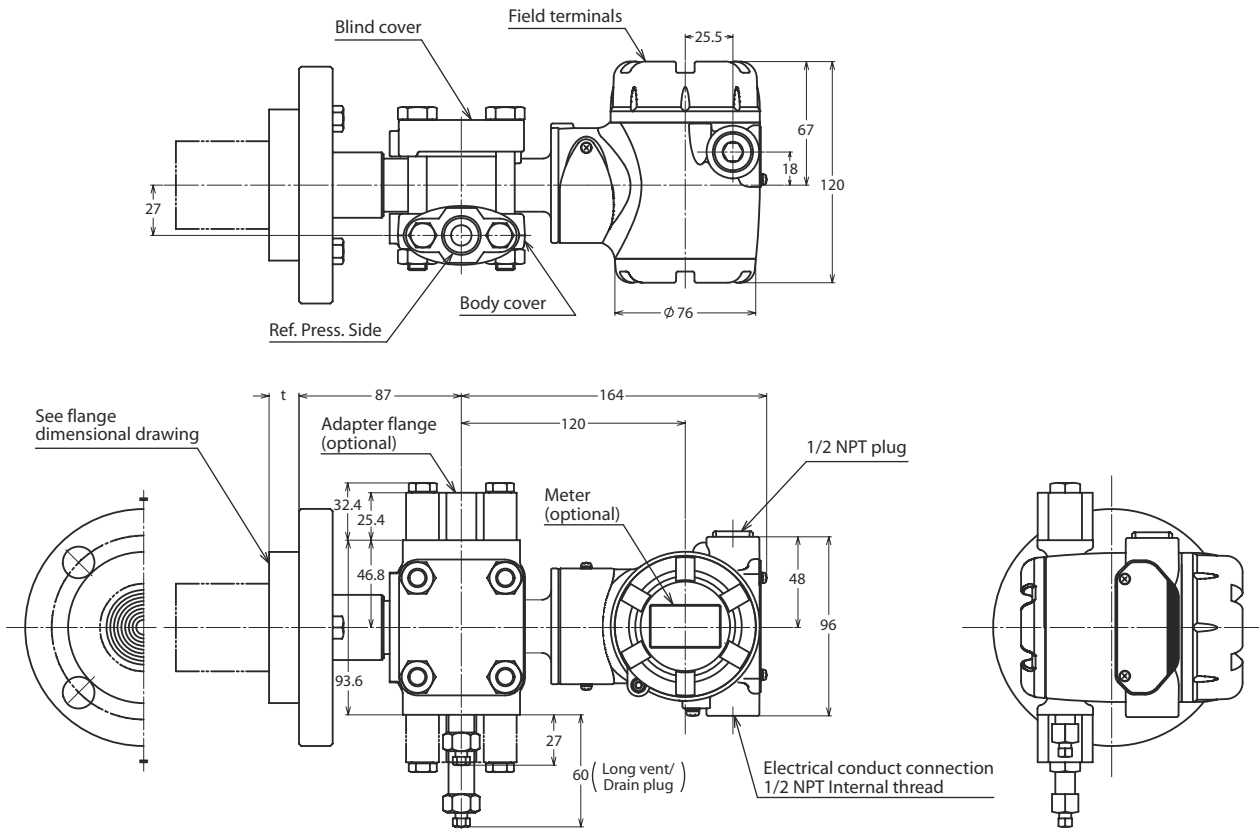

- Note) 1) For the process pipe connection on the standard pressure side, choose either the upward or downward directions. When changing the connection, replace the adapter flange and the vent/drain plugs.
- 2) Select a gasket that will not contact the diaphragm after it is tightened.

Model GTX35F/60F

Process connection of reference side: open to atmosphere

Process Connection

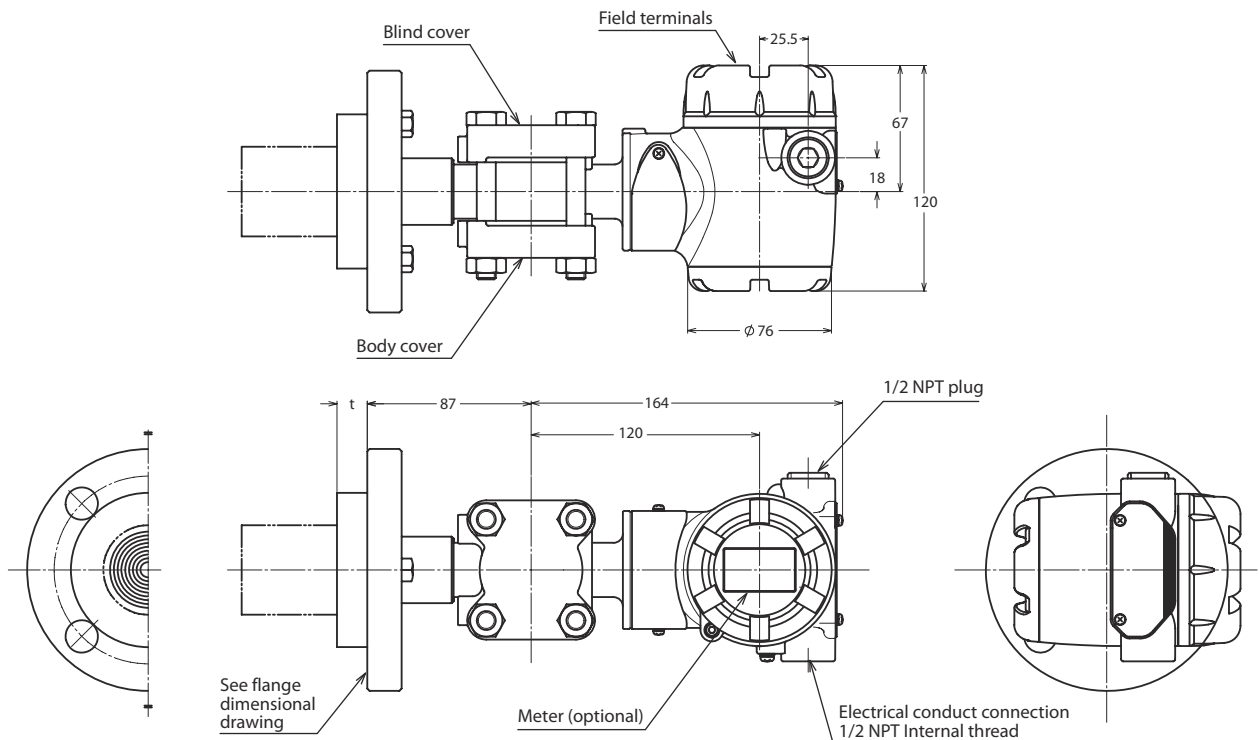

TERMINAL CONNECTION

(Not applicable for Fieldbus. See SS2-GTX00Z-0100 for Fieldbus.)

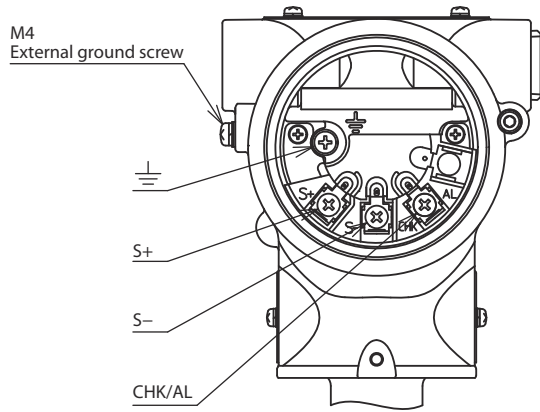

Table 1: Terminal connection

Symbol	Details
S+	Power supply and output signal +
S-	Power supply and output signal -/Check meter -
CHK/AL	Check meter +
⏏	Ground

Table 2: Terminal connection (option "07": Alarm output)

Symbol	Details
S+	Power supply and output signal +
S-	Power supply and output signal -
CHK/AL	Alarm +
⏏	Ground/Alarm -

Flush diaphragm flange

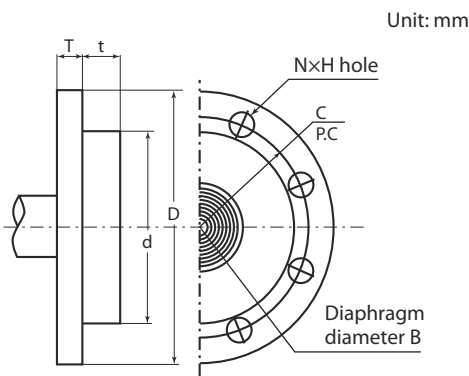

Material of wetted parts	B
316 SST	40
316L SST	
ASTM B575 (Hastelloy C-276 equivalent)	43
Tantalum	62

Rating	Flange rating	D	T	C	N	H	d	t
1.5 inch/ 40 mm	JIS 10K - 40 mm	140	18	105	4	19	81	16
	JIS 20K - 40 mm	140	18	105	4	19		
	JIS 30K - 40 mm	160	25	120	4	23		
	ANSI 150 - 1 1/2 inch	127	18	98.6	4	16		
	ANSI 300 - 1 1/2 inch	155	25	114.3	4	22		
	ANSI 600 - 1 1/2 inch	155	32	114.3	4	22		
	JPI 150 - 1 1/2 inch	127	18	98.6	4	16		
	JPI 300 - 1 1/2 inch	155	25	114.3	4	22		
2 inches/ 50 mm	JIS 10K - 50 mm	155	16	120	4	19	99	19
	JIS 20K - 50 mm	155	18	120	8	19		
	JIS 30K - 50 mm	165	22	130	8	19		
	ANSI 150 - 2 inches	152	19.5	120.6	4	19		
	ANSI 300 - 2 inches	165	22.5	127	8	19		
	ANSI 600 - 2 inches	165	25.5	127	8	19		
	JPI 150 - 2 inches	152	19.5	120.6	4	19		
	JPI 300 - 2 inches	165	22.5	127	8	19		
3 inches/ 80 mm	JIS 10K - 80 mm	185	18	150	8	19	129.5	22
	JIS 20K - 80 mm	200	22	160	8	23		
	JIS 30K - 80 mm	210	28	170	8	23		
	ANSI 150 - 3 inches	190	24	152.4	4	19		
	ANSI 300 - 3 inches	210	28.5	168.1	8	22		
	ANSI 600 - 3 inches	210	32	168.1	8	22		
	JPI 150 - 3 inches	190	24	152.4	4	19		
	JPI 300 - 3 inches	210	28.5	168.1	8	22		
JPI 600 - 3 inches	210	32	168.1	8	22			

External diaphragm flange

Unit: mm

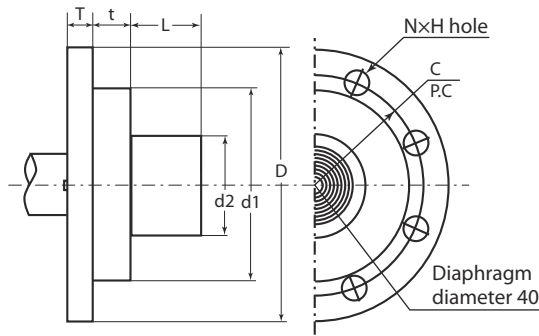

Rating	Flange rating	D	T	C	N	H	d1	d2	t	B
2 inches/50 mm	JIS 10K - 50 mm	155	16	120	4	19	99	47±1	19	40
	JIS 20K - 50 mm	155	18	120	8	19				
	JIS 30K - 50 mm	165	22	130	8	19				
	ANSI 150 - 2 inches	152	19.5	120.6	4	19				
	ANSI 300 - 2 inches	165	22.5	127	8	19				
	ANSI 600 - 2 inches	165	25.5	127	8	19				
	JPI 150 - 2 inches	152	19.5	120.6	4	19				
	JPI 300 - 2 inches	165	22.5	127	8	19				
	JPI 600 - 2 inches	165	25.5	127	8	19				
3 inches/80 mm	JIS 10K - 80 mm	185	18	150	8	19	129.5	69±1	22	40
	JIS 20K - 80 mm	200	22	160	8	23				
	JIS 30K - 80 mm	210	28	170	8	23				
	ANSI 150 - 3 inches	190	24	152.4	4	19				
	ANSI 300 - 3 inches	210	28.5	168.1	8	22				
	ANSI 600 - 3 inches	210	32	168.1	8	22				
	JPI 150 - 3 inches	190	24	152.4	4	19				
	JPI 300 - 3 inches	210	28.5	168.1	8	22				
	JPI 600 - 3 inches	210	32	168.1	8	22				
4 inches/100 mm	JIS 10K - 100 mm	210	18	175	8	19	157	95±1	23	40
	JIS 20K - 100 mm	225	24	185	8	23				
	JIS 30K - 100 mm	240	32	195	8	25				
	ANSI 150 - 4 inches	229	24	190.5	8	19				
	ANSI 300 - 4 inches	254	32	200.2	8	22				
	JPI 150 - 4 inches	229	24	190.5	8	19				
	JPI 300 - 4 inches	254	32	200.2	8	22				

L
50
100
150
200
250
300

Please, read 'Terms and Conditions' from following URL before the order and use.

<http://www.azbil.com/products/factory/order.html>

Specifications are subject to change without notice.

azbil

Azbil Corporation

Advanced Automation Company

1-12-2 Kawana, Fujisawa

Kanagawa 251-8522 Japan

URL: <http://www.azbil.com/>

1st edition: May 2008
19th edition: June 2017

No part of this publication may be reproduced or duplicated without the prior written permission of Azbil Corporation.