

AT9000 Advanced Transmitter

Differential Pressure Transmitters

OVERVIEW

AT9000 Advanced Transmitter is a microprocessor-based smart transmitter that features high performance and excellent stability. Capable of measuring gas, liquid, vapor, and liquid levels, it transmits 4 to 20 mA DC analog and digital signals according to the measured differential pressure.

It can also execute two-way communications between the communicator, thus facilitating selfdiagnosis, range resetting, and automatic zero/span adjustment.

SFN, HART® and FOUNDATION Fieldbus are available.

* Refer to SS2-GTX00Z-0100 for FOUNDATION Fieldbus type for the items marked with [☆].

FEATURES**High performance and stability**

- Unique characterization and composite semiconductor sensors realize high accuracy up to 0.04 % F.S.
- Our proven sensor technology enables Longterm stability up to 0.1 % of URL per 10-year.

Wide measuring range (range ability)

- A wide measuring range is available from a single model. This feature is highly effective in taking measurement over a wide range and reducing the need for inventory.
- Model GTX30D/31D/32D: 0.5 to 100 kPa (range ability: 200 to 1)

A diverse lineup

- A wide range of models is available to meet user requirements. They include draft range differential pressure, standard differential pressure, high differential pressure, standard differential pressure/high static pressure, and high differential pressure/high static pressure models.
- A wide variety of corrosion-resistant materials for wetted parts is also available.

**Remote communication**

- Two-way communication using digital output facilitates self-diagnosis, range resetting, automatic zero adjustment, and other operations.
- HART® protocol communication is available. (Option)

China RoHS

This device is used in the Oil & Gas, Petrochemical, Chemical, Pulp & Paper, Food & Beverage, Machinery, Steel/Metal & Mining, and Automobile industries and therefore does not fall under the China RoHS Legislation.

If this device is used in semiconductor manufacturing equipment, labeling on the device and documents for the China RoHS may be required. If such documents are required, consult an Azbil Corp. representative.

HART® is a registered trademark of the FieldComm Group.

FOUNDATION™ is a registered trademark of the FieldComm Group.

PRODUCT APPROVALS [☆]**FM Explosionproof for Division System/
Flameproof for Zone System (Code F1)**

Explosionproof for Class I, Division 1, Groups A, B, C and D; Class I, Zone 1, AEx d IIC

Dust-Ignitionproof for Class II, III, Division 1, Groups E, F and G

T5 $-40\text{ °C} \leq T_{amb} \leq +85\text{ °C}$

Hazardous locations

Indoor/Outdoor Type 4X, IP67

Factory sealed, conduit seal not required for Division applications

Caution - Use supply wires suitable for 5 °C above surrounding ambient

FM Intrinsic Safety (Code F2)

IS/I, II, III/1/ABCDEFGH/T4; $-40\text{ °C} \leq T_{amb} \leq +60\text{ °C}$;
80395278, 80395279, 80395280; Entity; TYPE 4X; IP67

I/0/AEx ia/IIC/T4; $-40\text{ °C} \leq T_{amb} \leq +60\text{ °C}$; 80395278,
80395279, 80395280; Entity; TYPE 4X; IP67

Entity Parameters: V_{max} (U_i)=30 Volts, I_{max} (I_i)=100 mA,
 P_i =1 W, C_i =10 nF, L_i =0.5 mH

FM Nonincendive (Code F5)

NI/I/2/ABCD/T4; $-40\text{ °C} \leq T_{amb} \leq +60\text{ °C}$; 80395494; NIFW;
TYPE 4X; IP67

NI/I/2/IIC/T4; $-40\text{ °C} \leq T_{amb} \leq +60\text{ °C}$; 80395494; NIFW;
TYPE 4X; IP67

S/II, III/1/EFG/T4; $-40\text{ °C} \leq T_{amb} \leq +60\text{ °C}$;
80395494; NIFW; TYPE 4X; P67

Nonincendive Field Wiring Parameters:

V_{max} (U_i)=30 Volts, C_i =10 nF, L_i =0.5 mH

Combination of F1, F2 and F5 (Code F6)**ATEX Flameproof (Code A1)**

KEMA 08ATEX0004

II 1/2 G Ex d IIC T6 $T_{process}=85\text{ °C}$
 $-30\text{ °C} \leq T_{amb} \leq +75\text{ °C}$ IP66/67

II 1/2 G Ex d IIC T5 $T_{process}=100\text{ °C}$
 $-30\text{ °C} \leq T_{amb} \leq +80\text{ °C}$ IP66/67

II 1/2 G Ex d IIC T4 $T_{process}=110\text{ °C}$
 $-30\text{ °C} \leq T_{amb} \leq +80\text{ °C}$ IP66/67

II 2 D Ex tD A21 IP66/67 T85 $T_{process}=85\text{ °C}$
 $-30\text{ °C} \leq T_{amb} \leq +75\text{ °C}$

II 2 D Ex tD A21 IP66/67 T100 $T_{process}=100\text{ °C}$
 $-30\text{ °C} \leq T_{amb} \leq +75\text{ °C}$

II 2 D Ex tD A21 IP66/67 T110 $T_{process}=110\text{ °C}$
 $-30\text{ °C} \leq T_{amb} \leq +75\text{ °C}$

Caution - Use supply wires suitable for 5 °C above surrounding ambient

ATEX Intrinsic Safety (Code A2)

KEMA 07ATEX0200 X

II 1 G Ex ia IIC T4 $T_{process}=105\text{ °C}$
 $-30\text{ °C} \leq T_{amb} \leq +60\text{ °C}$ IP66/67

Electrical Parameters: $U_i=30\text{ V}$, $I_i=93\text{ mA}$, $P_i=1\text{ W}$, $C_i=5\text{ nF}$,
 $L_i=0.5\text{ mH}$

II 1 D Ex iaD 20 IP66/67 T105 $T_{process}=105\text{ °C}$
 $-30\text{ °C} \leq T_{amb} \leq +60\text{ °C}$

NEPSI Flameproof (Code N1)

Ex d IIC T6 DIP A21 T_A 85 °C $T_{process}=80\text{ °C}$
 $-30\text{ °C} \leq T_{amb} \leq +75\text{ °C}$

Ex d IIC T5 DIP A21 T_A 100 °C $T_{process}=95\text{ °C}$
 $-30\text{ °C} \leq T_{amb} \leq +80\text{ °C}$

Ex d IIC T4 DIP A21 T_A 115 °C $T_{process}=110\text{ °C}$
 $-30\text{ °C} \leq T_{amb} \leq +80\text{ °C}$

ENCLOSURE TYPE IP66/67

NEPSI Intrinsic Safety (Code N2)

Ex ia IIC T4 $T_{process}=105\text{ °C}$
 $-30\text{ °C} \leq T_{amb} \leq +60\text{ °C}$

Enclosure IP66/67

Electrical Parameters: $U_i=30\text{ V}$, $I_i=100\text{ mA}$, $P_i=1\text{ W}$,
 $C_i=13\text{ nF}$, $L_i=0.5\text{ mH}$

NEPSI Type n (Code N5)

Ex nL IIC T4 $T_{process}=110\text{ °C}$
 $-30\text{ °C} \leq T_{amb} \leq +60\text{ °C}$

Enclosure IP66/67

Electrical Parameters: $U_i=30\text{ V}$, $I_i=100\text{ mA}$, $P_i=1\text{ W}$,
 $C_i=13\text{ nF}$, $L_i=0.5\text{ mH}$

IECEx Flameproof (Code E1)

Certificate No. IECEx KEM 08.0001
Ga/Gb Ex d IIC T6 $T_{process}=85\text{ °C}$
 $-30\text{ °C} \leq T_{amb} \leq +75\text{ °C}$ IP66/67

Ga/Gb Ex d IIC T5 $T_{process}=100\text{ °C}$
 $-30\text{ °C} \leq T_{amb} \leq +80\text{ °C}$ IP66/67

Ga/Gb Ex d IIC T4 $T_{process}=110\text{ °C}$
 $-30\text{ °C} \leq T_{amb} \leq +80\text{ °C}$ IP66/67

Ex tD A21 IP66/67 T85 $T_{process}=85\text{ °C}$
 $-30\text{ °C} \leq T_{amb} \leq +75\text{ °C}$

Ex tD A21 IP66/67 T100 $T_{process}=100\text{ °C}$
 $-30\text{ °C} \leq T_{amb} \leq +75\text{ °C}$

Ex tD A21 IP66/67 T110 $T_{process}=110\text{ °C}$
 $-30\text{ °C} \leq T_{amb} \leq +75\text{ °C}$

Caution - Use supply wires suitable for 5 °C above surrounding ambient

IECEx Intrinsic Safety (Code E2)

IECEx KEM 07.0058X

Zone 0 Ex ia IIC T4 $T_{process}=105\text{ °C}$
 $-30\text{ °C} \leq T_{amb} \leq +60\text{ °C}$ IP66/67

Electrical Parameters: $U_i=30\text{ V}$, $I_i=93\text{ mA}$, $P_i=1\text{ W}$, $C_i=5\text{ nF}$,
 $L_i=0.5\text{ mH}$

Ex iaD 20 IP66/67 T105 $T_{process}=105\text{ °C}$
 $-30\text{ °C} \leq T_{amb} \leq +60\text{ °C}$

KOSHA Flameproof (Code K1)Ex d II C T6 T_{process}=85 °C-30 °C ≤ T_{amb} ≤ +75 °CEx d II C T5 T_{process}=100 °C-30 °C ≤ T_{amb} ≤ +80 °CEx d II C T4 T_{process}=110 °C-30 °C ≤ T_{amb} ≤ +80 °C**EMC Conformity [☆]**

EN 61326-1 (industrial electromagnetic environment)

EN 61326-2-3

PED Conformity (97/23EC)

The maximum pressures applicable under the Sound Engineering Practice (SEP) section of the Pressure Equipment Directive depend on the type of fluid measured, as shown in the table below.

Measured fluid	Group*	Pressure	Applicable models
Gas	1	200 bar (20 MPa)	All models except GTX32D, 42D, 72D, 82G
	2	1,000 bar (100 MPa)	All models
Liquid	1	500 bar (50 MPa)	All models
	2	1,000 bar (100 MPa)	All models

Note) Group 1 comprises fluids defines as: explosive, extremely flammable, highly flammable, flammable, very toxic, toxic and oxidizing.

Group 2 comprises all other fluids not refer to group 1

Any AT9000 model having a maximum working pressure that is higher than the pressure corresponding to its group does not conform to SEP.

Models GTX32D, 42D, 72D conform to PED according to Module A.

FUNCTIONAL SPECIFICATIONS**Type of protection**

NEMA 3 and 4X

IEC IP66/67

Measuring span/Setting range

Model	Measuring Span	Setting Range
GTX15D	0.1 to 2 kPa {10 to 200 mmH ₂ O}	-1 to +1 kPa {-100 to +100 mmH ₂ O}
GTX30D	0.5 to 100 kPa {50 to 10160 mmH ₂ O}	-100 to +100 kPa {-10160 to +10160 mmH ₂ O}
GTX31D	0.5 to 100 kPa {50 to 10160 mmH ₂ O}	-100 to +100 kPa {-10160 to +10160 mmH ₂ O}
GTX32D	0.5 to 100 kPa {50 to 10160 mmH ₂ O}	-100 to +100 kPa {-10160 to +10160 mmH ₂ O}
GTX40D	35 to 700 kPa {0.35 to 7 kgf/cm ² }	-100 to +700 kPa {-1 to +7 kgf/cm ² }
GTX41D	35 to 700 kPa {0.35 to 7 kgf/cm ² }	-100 to +700 kPa {-1 to +7 kgf/cm ² }
GTX42D	35 to 700 kPa {0.35 to 7 kgf/cm ² }	-100 to +700 kPa {-1 to +7 kgf/cm ² }
GTX71D	0.25 to 14 MPa {2.5 to 140kgf/cm ² }	-0.1 to +14 MPa {-1 to +140 kgf/cm ² }
GTX72D	0.25 to 14 MPa {2.5 to 140 kgf/cm ² }	-0.1 to +14 MPa {-1 to +140 kgf/cm ² }

Working pressure range

Model	Working pressure range
GTX15D	-70 to +210 kPa {-0.7 to +2.1 kgf/cm ² }
GTX30D	2.0 kPa abs to 3.5 MPa {15 mmHg abs to 35 kgf/cm ² } ^{*1}
GTX31D	2.0 kPa abs to 21 MPa {15 mmHg abs to 210 kgf/cm ² } ^{*1 *2} (For vacuum pressure, see Figure 1, 2)
GTX32D	2.0 kPa abs to 42 MPa {15 mmHg abs to 420 kgf/cm ² } ^{*3} (For vacuum pressure, see Figure 1, 2)
GTX40D	2.0 kPa abs to 3.5 MPa {15 mmHg abs to 35 kgf/cm ² } ^{*1}
GTX41D	2.0 kPa abs to 21 MPa {15 mmHg abs to 210 kgf/cm ² } ^{*1 *2} (For vacuum pressure, see Figure 1, 2)
GTX42D	2.0 kPa abs to 42 MPa {15 mmHg abs to 420 kgf/cm ² } ^{*3} (For vacuum pressure, see Figure 1, 2)
GTX71D	2.0 kPa abs to 20 MPa {15 mmHg abs to 210 kgf/cm ² } ^{*1 *2} (For vacuum pressure, see Figure 1, 2)
GTX72D	2.0 kPa abs to 42 MPa {15 mmHg abs to 420 kgf/cm ² } ^{*3} (For vacuum pressure, see Figure 1, 2)

Note) *1. With PVC wetted parts, the maximum working pressure is 1.5 MPa {15 kgf/cm²}.

*2 With 304 SST SST bolts and nuts, the maximum working pressure is 10 MPa {100 kgf/cm²}.

*3 With 304 SST SST bolts and nuts, the maximum working pressure is 20 MPa {200 kgf/cm²}.

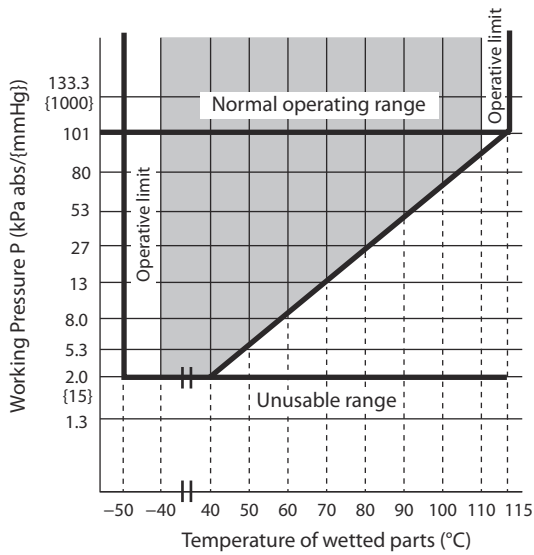

Figure 1. Working pressure and temperature of wetted parts section (for general purpose models)

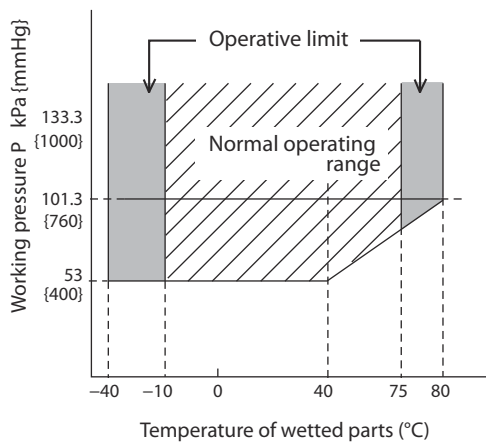

Figure 2. Working pressure and temperature of wetted parts section (for oxygen and chlorine service)

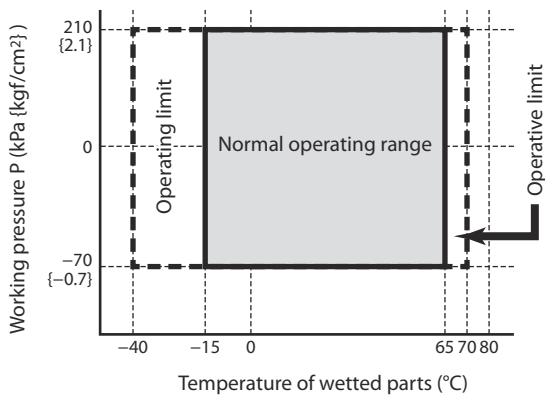

Figure 3. Working pressure and temperature of wetted parts section (for model GTX15D regular type)

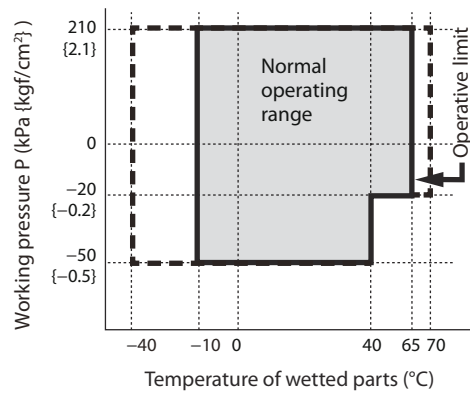

Figure 4. Working pressure and temperature of wetted parts section (for model GTX15D oxygen service)

Power Supply [☆]

12.5 to 42 V DC

Limited to 12.5 to 30 V DC for intrinsic safety, Type n, Non-incendive types

Power Supply voltage and load resistance characteristics [☆]

See Figure 5.

Limited to Load resistance: 250 to 1345 Ω for SFN or DE communication. 250 to 600 Ω for HART communication.

Power supply voltage: 12.5 to 30 V DC for intrinsic safety, Type n, Nonincendive types

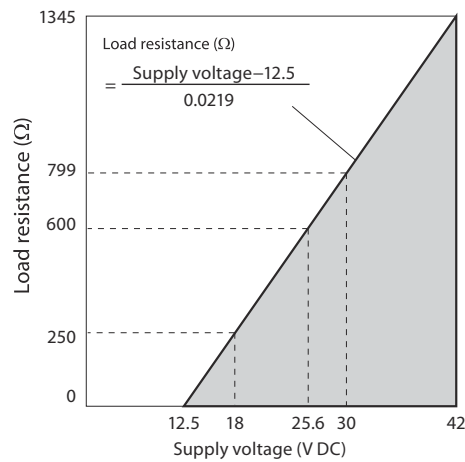

Figure 5. Power supply voltage vs. Load resistance

Note) For communication with a communicator, a load resistance of 250 Ω or more is necessary.

Output [☆]

- Analog output (4 to 20 mA DC) with SFN
- Analog output (4 to 20 mA DC) with HART
- Digital output (DE protocol)

Output signal [☆]

- 3.6 to 21.6 mA
- 3.8 to 20.5 mA (NAMUR NE43 compliant)

Failure Alarm [☆]

- Upper: 21.6 mA or more
- Lower: 3.6 mA or less

Ambient temperature limit**Normal operating range**

–40 to +85 °C for general purpose models
 –15 to +65 °C for general purpose model (model GTX15D)
 –15 to +85 °C for general purpose model (model GTX32D/42D/72D)
 –10 to +75 °C for oxygen and chlorine models
 –10 to +65 °C for oxygen and chlorine model (model GTX15D)
 –25 to +80 °C for model with digital indicators
 –15 to +65 °C for model with digital indicators (model GTX15D)
 –15 to +80 °C for model with digital indicators (model GTX32D/42D/72D)
 0 to +55 °C for models with PVC meterbody covers

Operative limits

–50 to +93 °C for general purpose models
 –40 to +70 °C for general purpose model (model GTX15D)
 –25 to +93 °C for general purpose model (model GTX32D/42D/72D)
 –40 to +80 °C for oxygen and chlorine models
 –30 to +85 °C for models with digital indicators
 –40 to +70 °C for models with digital indicators (model GTX15D)
 –25 to +85 °C for models with digital indicators (model GTX32D/42D/72D)
 –10 to +60 °C for models with PVC meterbody covers

Transportation and storage conditions

–50 to +85 °C for general purpose models
 –15 to +65 °C for general purpose model (model GTX15D)
 –15 to +85 °C for general purpose model (model GTX32D/42D/72D)
 –10 to +60 °C for models with PVC meterbody covers

Temperature ranges of wetted parts**Normal operating range**

–40 to +110 °C for general purpose models
 –15 to +65 °C for general purpose model (model GTX15D)
 –15 to +110 °C for general purpose model (model GTX32D/42D/72D)
 –20 to +75 °C for oxygen and chlorine models
 –15 to +65 °C for oxygen and chlorine model (model GTX15D)
 –15 to +75 °C for oxygen and chlorine model (model GTX32D/42D/72D)
 0 to +55 °C for models with PVC meterbody covers

Operative limits

–50 to +115 °C for general purpose models
 –40 to +70 °C for general purpose model (model GTX15D)
 –20 to +115 °C for general purpose model (model GTX32D/42D/72D)
 –40 to +80 °C for oxygen and chlorine models
 –40 to +70 °C for oxygen and chlorine models (model GTX15D)
 –20 to +80 °C for oxygen and chlorine models (model GTX32D/42D/72D)
 –10 to +60 °C for models with PVC meterbody covers

Ambient humidity limits

5 to 100 % RH

Stability against supply voltage change

±0.005 % FS/V

Response time [☆]

Below 100 msec. (model GTX30D/31D, when damping time is set to 0 sec.)

Below 150 msec. (other models, when damping time is set to 0 sec.)

Damping time [☆]

Selectable from 0 to 128 sec. (HART)

Selectable from 0 to 32 sec. in ten stages (SFN)

Zero Stability

±0.1 % of URL per 10 year (GTX30D/31D/32D/40D/41D/42D)

±0.2 % of URL per 10 year (GTX71D/72D)

±1.0 % of URL per 10 year (GTX15D)

Lightning protection [☆]

Applicable Standards; IEC 61000-4-5

Peak value of current surge (80/20 μ sec.): 6000 A

Indicator

The digital LCD indicator (optional) shows the output in percentage or in engineering units. Range for engineering unit is from -99999 to 99999 when set at the factory, and from -19999 to 19999 when using the communicator. Specify the following items when placing order with engineering units,

- Pressure range
- Engineering unit of pressure
- Method of display, either linear or square-root. These data may be set or changed using the communicator.

OPTIONAL SPECIFICATIONS

Oil free finish

The transmitter is shipped with oil-free wetted parts.

Adapters for anticorrosion materials

These are adaptor flanges to connect 82 mm pipes made of anticorrosion materials [excluding ASTM B575 (Equivalent to Hastelloy C-276)] to 54 mm general-purpose pipes.

External zero/span adjustment function

The transmitter can be easily adjusted to zero or span in the field.

Indicator must be selected to enable this option.

Fieldbus type does not have span adjustment.

Elbow

This is an adaptor for changing the electrical conduit connection port from the horizontal to the vertical direction, if required by wiring conditions in the field. One or two elbows may be used as needed.

Conformance to Non SI units

We deliver transmitters set to any Non SI units as specified.

Safety Transmitter

Select this option to be used as a component of Safety Instrument System (SIS).

AT9000 is complied with IEC 61508, certified according to Safety Integrity Level 2 (SIL-2).

This option is not applicable for FOUNDATION Fieldbus type, DE communication type, external zero/span adjustment (option A2), and Alarm output (option Q7).

Alarm Output (contact output)

Contact output is prepared as alarm output when alarm (Output Alarm/Sensor Temp. Alarm) condition is detected. It can be set to or Normally Close.

Contact output type : One open collector (NPN)

Contact rating: 30 V DC max., 30 mA DC max.

Residual voltage at output ON: 3.0 V max.

Operating mode: Normally Open (default)

Normally Close is not recommended.

When this option is selected, CHECK terminals for current check cannot be used.

This option is not applicable for FOUNDATION Fieldbus type, and with intrinsic safety, Type n, Nonincendive types.

Advanced diagnostics [☆]

This option is applicable for FOUNDATION Fieldbus type. Refer to SS2-GTX00Z-0100.

Custom calibration

Calibrate for the specified pressure range at the factory.

PHYSICAL SPECIFICATIONS

Materials

Fill fluid

Silicone oil for general purpose models

Fluorine oil for oxygen and chlorine models

Center body

316 SST

Transmitter case

Aluminum alloy, CF8M (Equivalent to 316 SST)

Meter body cover flange

SCS14A (Equivalent to 316 SST) or 316 SST, PVC

Bolts and nuts (for fastening meter body cover)

Carbon steel (SNB7), 304 SST, 316 SST, 630 SST

O-ring

NBR

For Wetted parts

Adapter flange (option)

SCS14A (Equivalent to 316 SST), PVC

Center body

316 SST (Diaphragm 316L SST)

ASTM B575 (Equivalent to Hastelloy C-276), Tantalum, 316L SST

Vents and plugs

316 SST, PVC

Gaskets

PTFE

Mounting Bracket

Bracket

Carbon steel, 304SST

U-bolt and nuts

304 SST

Paint

Standard: Baked acrylic paint

Corrosion-proof: Baked urethane paint

Color

Housing: Silver N-8.2

Cap: azbil bordeaux 2.5R 2.25/5

Weight

Approx. 3.4 kg (model GTX30D/40D)

Approx. 3.7 kg (model GTX31D/41D/71D)

Approx. 6.3 kg (model GTX32D/42D/72D)

INSTALLATION

Electrical connection

1/2 NPT internal thread, M20 internal thread.

Grounding

Resistance 100 Ω max.

Mounting

Can be installed on a 2-inch horizontal or vertical pipe (can be directly mounted on a process pipe)

Process connection

Rc 1/2, 1/2 NPT internal thread and Rc 1/4, 1/4 NPT internal thread.

TRANSMITTER HANDLING NOTES

To get the most from the performance this transmitter can offer, please use it properly noting the points mentioned below. Before using it, please read the Instruction Manual.

Transmitter installation notes

WARNING

- When installing the transmitter, ensure that gaskets do not protrude from connecting points into the process (such as adapter flange connection points and connecting pipes and flanges). Failure to do so may cause a leak of process fluid, resulting in harm from burns, etc. In addition, if the process fluid contains toxic substances, take safety measures such as wearing goggles and a mask to prevent contact with the skin and eyes and to prevent inhalation.
- Use the transmitter within the operating ranges stated in the specifications (for explosion-proofing, pressure rating, temperature, humidity, voltage, vibration, shock, mounting direction, atmosphere, etc.). Using the transmitter outside the operating conditions may cause device failure or fire, resulting in a harmful physical risk of burning or the like.
- When performing wiring work in explosion-proof areas, follow the work method specified in the explosion-proof guidelines.

CAUTION

- After installation, do not use the transmitter as a foothold or put your weight on it. Doing so may cause damage.
- Be careful not to hit the glass indicator with tools etc. This could break the glass and cause injury.
- The transmitter is heavy. Wear safety shoes and take care when installing it.
- Impact to transmitter can damage sensor module.

Wiring notes

WARNING

- To avoid shocks, do not perform electrical wiring work with wet hands or with live wires.

CAUTION

- Do wiring work properly in conformance with the specifications. Wiring mistakes may result in malfunction or irreparable damage to the instrument.
- Use a power supply that conforms to the specifications. Use of an improper power supply may result in malfunction or irreparable damage to the instrument.
- Use a power supply with overcurrent protection for this instrument.

Handling precautions for HART specification devices

- If you need to operate with a secondary host (HART communicator, etc.), set the communication interval of the primary host (DCS, device management system) to 8 seconds or more, or suspend communication from the primary host. If the primary host repeats HART communication within 8 seconds, the request from the secondary host may not be received (communication may not be possible).
- If electrical noise in the environment prevents HART communications with the host, take countermeasures such as separating the signal cables from the source of the noise, improving the grounding, changing to shielded signal cables, etc. Even if noise interferes with HART communications, the 4–20 mA analog signal will be unaffected and can be used for control.
- If this product is being operated in multidrop mode, there is a limit to the number of devices that can be used. If you are using multidrop mode, please consult with us.

PERFORMANCE SPECIFICATIONS

Reference accuracy

Shown for each item are the percentage ratio for x (kPa), which is the greatest value of either the upper range value (URV)^{*1}, the lower range value (LRV)^{*2} or the span.

For FOUNDATION Fieldbus type, read URV as XD_SCALE “EU_100” and LRV as XD_SCALE “EU_0”.

Model GTX15D

Material of wetted parts: Diaphragm; 316L SST, Others; 316 SST

Reference accuracy ^{*4}	Linear output:	$\pm \left(0.15 + 0.15 \times \frac{1.0}{x} \right) \%$
	Square-root output:	When output is 50 to 100 %: same as linear output When output is 7.1 to 50 %: linear output $\times \frac{50}{\text{square} - \text{root} \cdot \text{output}} \%$ When output is less than 7.1 %: dropout
Ambient Temperature effect (Shift from the set range) Change of 30 °C (Range from -5 to +55 °C)	Combined shift: (including zero and span shifts)	$\pm \left(0.19 + 0.56 \times \frac{1.0}{x} \right) \%$
Static pressure effect (Shift with respect to Setting range) Change of 70 kPa {0.7 kgf/cm ² }	Zero shift:	$\pm \left(0.03 + 0.4 \times \frac{1}{x} \right) \%$
	Combined shift: (including zero and span shifts)	$\pm \left(0.03 + 0.45 \times \frac{1}{x} \right) \%$

Model GTX30D/31D (for regular type)

Material of wetted parts: Diaphragm; 316L SST, Others; 316 SST

Reference accuracy ^{*3 *4 *5}	Linear output:	$\pm 0.04 \%$ (For $x \geq 10.0$ kPa {1000 mmH ₂ O}) $\pm \left(0.008 + 0.032 \times \frac{10}{x} \right) \%$ (For $x < 10$ kPa {1000 mmH ₂ O})
	Square-root output:	When output is 50 to 100 %: same as linear output When output is 7.1 to 50 %: linear output $\times \frac{50}{\text{square} - \text{root} \cdot \text{output}} \%$ When output is less than 7.1 %: dropout
Ambient Temperature effect (Shift from the set range) ^{*3} Change of 30 °C (Range from -5 to +55 °C)	Combined shift: (including zero and span shifts)	$\pm 0.15 \%$ (For $x \geq 12.5$ kPa {1250 mmH ₂ O}) $\pm \left(0.075 + 0.075 \times \frac{12.5}{x} \right) \%$ (For $x \leq 12.5$ kPa {1250 mmH ₂ O})
Static pressure effect (Shift with respect to Setting range) ^{*3} Change of 7 MPa {70 kgf/cm ² }	Zero shift:	$\pm \left(0.03 + 0.17 \times \frac{A}{x} \right) \%$ A= 12.5 (GTX30D/31D) 20 (GTX32D)
	Combined shift: (including zero and span shifts)	$\pm \left(0.03 + 0.37 \times \frac{A}{x} \right) \%$

*1. URV denotes the process value for 100 % (20 mA DC) output.

*2. LRV denotes the process value for 0 % (4 mA DC) output.

*3. Within a range of $URV \geq 0$ and $LRV \geq 0$.

*4. Reference accuracy at calibrated condition.

*5. In case code D “Digital output (DE communication)” is selected, reference accuracy becomes the same as one of “for oxygen/chlorine service”.

Model GTX30D/31D (for oxygen/chlorine service)

Material of wetted parts: Diaphragm; 316L SST, Others; 316 SST

Reference accuracy *3 *4	Linear output:	$\pm 0.075\%$ (For $x \geq 50.0$ kPa {5000 mmH ₂ O}) $\pm 0.1\%$ (For 50.0 kPa {5000 mmH ₂ O} $> x \geq 5.0$ kPa {500 mmH ₂ O}) $\pm \left(0.025 + 0.075 \times \frac{5.0}{x} \right) \%$ (For $x \geq 5.0$ kPa {500 mmH ₂ O})
	Square-root output:	When output is 50 to 100 %: same as linear output When output is 7.1 to 50 %: linear output $\times \frac{50}{\text{square-root} \cdot \text{output}} \%$ When output is less than 7.1 %: dropout
Ambient Temperature effect (Shift from the set range) Change of 30 °C *3 (Range from -5 to +55 °C)	Combined shift: (including zero and span shifts)	$\pm 0.44\%$ (For $x \geq 12.5$ kPa {1250 mmH ₂ O}) $\pm \left(0.19 + 0.25 \times \frac{12.5}{x} \right) \%$ (For $x \leq 12.5$ kPa {1250 mmH ₂ O})
Static pressure effect (Shift with respect to Setting range) *3 Change of 7 MPa {70 kgf/cm ² }	Zero shift:	$\pm \left(0.03 + 0.17 \times \frac{20}{x} \right) \%$
	Combined shift: (including zero and span shifts)	$\pm 0.4\%$ (For $x \geq 20.0$ kPa {2000 mmH ₂ O}) $\pm \left(0.03 + 0.37 \times \frac{20}{x} \right) \%$ (For $x < 20.0$ kPa {2000 mmH ₂ O})

Model GTX30D/31D

Material of wetted parts: Diaphragm; ASTM B575 (Equivalent to Hastelloy C-276), Tantalum, 316L SST Others; ASTM B575 (Equivalent to Hastelloy C-276), Tantalum, 316L SST

Reference accuracy *3 *4	Linear output:	$\pm 0.2\%$ (For $x \geq 10$ kPa {1000 mmH ₂ O}) $\pm \left(0.125 + 0.075 \times \frac{10}{x} \right) \%$ (For $x \geq 10$ kPa {1000 mmH ₂ O})
	Square-root output:	When output is 50 to 100 %: same as linear output When output is 7.1 to 50 %: linear output $\times \frac{50}{\text{square-root} \cdot \text{output}} \%$ When output is less than 7.1 %: dropout
Ambient Temperature effect (Shift from the set range) Change of 30 °C *3 (Range from -5 to +55 °C)	Combined shift: (including zero and span shifts)	$\pm \left(0.55 + 0.65 \times \frac{20.0}{x} \right) \%$
Static pressure effect (Shift with respect to Setting range) *3 Change of 7 MPa {70 kgf/cm ² }	Zero shift:	$\pm \left(0.03 + 0.62 \times \frac{20.0}{x} \right) \%$
	Combined shift: (including zero and span shifts)	$\pm \left(0.55 + 0.45 \times \frac{20.0}{x} \right) \%$ ($x \geq 20.0$ kPa {2000 mmH ₂ O}) $\pm \left(0.18 + 0.82 \times \frac{20.0}{x} \right) \%$ ($x < 20.0$ kPa {2000 mmH ₂ O})

*3. Within a range of URV ≥ 0 and LRV ≥ 0 .

*4. Reference accuracy at calibrated condition.

*5. In case code D "Digital output (DE communication)" is selected, reference accuracy becomes the same as one of "for oxygen/chlorine service".

Model GTX32D

Material of wetted parts: Diaphragm; 316L SST, Others; 316 SST

Reference accuracy *4	Linear output:	$\pm 0.075\%$ (For $x \geq 50.0$ kPa {5000 mmH ₂ O}) $\pm 0.1\%$ (For 50.0 kPa {5000 mmH ₂ O} $> x \geq 5.0$ kPa {500 mmH ₂ O}) $\pm \left(0.025 + 0.075 \times \frac{5.0}{x} \right) \%$ (For $x < 5.0$ kPa {500 mmH ₂ O})
	Square-root output:	When output is 50 to 100 %: same as linear output When output is 7.1 to 50 %: linear output $\times \frac{50}{\text{square-root} \cdot \text{output}} \%$ When output is less than 7.1 %: dropout
Ambient Temperature effect (Shift from the set range) Change of 30 °C *3	Combined shift: (including zero and span shifts)	$\pm 0.41\%$ (For $x \geq 12.5$ kPa {1250 mmH ₂ O}) $\pm \left(0.18 + 0.23 \times \frac{12.5}{x} \right) \%$ (For $x \leq 12.5$ kPa {1250 mmH ₂ O})
Static pressure effect (Shift with respect to Setting range) *3 Change of 7 MPa {70 kgf/cm ² }	Zero shift:	$\pm \left(0.03 + 0.17 \times \frac{20}{x} \right) \%$
	Combined shift: (including zero and span shifts)	$\pm 0.4\%$ (For $x \geq 20.0$ kPa {2000 mmH ₂ O}) $\pm \left(0.03 + 0.37 \times \frac{20}{x} \right) \%$ (For $x < 20.0$ kPa {2000 mmH ₂ O})

Model GTX40D/41D/42D

Material of wetted parts: Diaphragm; 316L SST, Others; 316 SST

Reference accuracy *3 *4	Linear output:	$\pm 0.1\%$ (For $x \geq 140$ kPa {1.4 kgf/cm ² }) $\pm \left(0.025 + 0.075 \times \frac{140}{x} \right) \%$ (For $x < 140$ kPa {1.4 kgf/cm ² })
	Square-root output:	When output is 50 to 100 %: same as linear output When output is 7.1 to 50 %: linear output $\times \frac{50}{\text{square-root} \cdot \text{output}} \%$ When output is less than 7.1 %: dropout
Ambient Temperature effect (Shift from the set range) Change of 30 °C *3 (Range from -5 to +55 °C)	Combined shift: (including zero and span shifts)	$\pm 0.41\%$ (For $x \geq 210$ kPa {2.1 kgf/cm ² }) $\pm \left(0.18 + 0.23 \times \frac{210}{x} \right) \%$ (For $x < 210$ kPa {2.1 kgf/cm ² })
Static pressure effect (Shift with respect to Setting range) *3 Change of 7 MPa {70 kgf/cm ² }	Zero shift:	$\pm \left(0.03 + 0.17 \times \frac{700}{x} \right) \%$
	Combined shift: (including zero and span shifts)	$\pm 0.33\%$ (For $x \geq 700$ kPa {7.1 kgf/cm ² }) $\pm \left(0.03 + 0.37 \times \frac{700}{x} \right) \%$ (For $x < 700$ kPa {7.1 kgf/cm ² })

Model GTX40D/41D

Material of wetted parts: Diaphragm; ASTM B575 (Equivalent to Hastelloy C-276), Tantalum, 316L SST Others; ASTM B575 (Equivalent to Hastelloy C-276), Tantalum, 316L SST

Reference accuracy *3 *4	Linear output:	$\pm 0.2\%$ ($x \geq 140$ kPa {1.4 kgf/cm ² }) $\pm \left(0.125 + 0.075 \times \frac{140}{x} \right) \%$ (For $x < 140$ kPa {1.4 kgf/cm ² })
	Square-root output:	When output is 50 to 100 %: same as linear output When output is 7.1 to 50 %: linear output $\times \frac{50}{\text{square-root} \cdot \text{output}} \%$ When output is less than 7.1 %: dropout
Ambient Temperature effect (Shift from the set range) Change of 30 °C *3 (Range from -5 to +55 °C)	Combined shift: (including zero and span shifts)	$\pm 1.20\%$ ($x \geq 210$ kPa {2.1 kgf/cm ² }) $\pm \left(0.55 + 0.65 \times \frac{210}{x} \right) \%$ (For $x < 210$ kPa {2.1 kgf/cm ² })
Static pressure effect (Shift with respect to Setting range) *3 Change of 7 MPa {70 kgf/cm ² }	Zero shift:	$\pm \left(0.03 + 0.295 \times \frac{700}{x} \right) \%$
	Combined shift: (including zero and span shifts)	$\pm \left(0.08 + 0.495 \times \frac{700}{x} \right) \%$

*3. Within a range of URV ≥ 0 and LRV ≥ 0 .

*4. Reference accuracy at calibrated condition.

Model GTX71D/72D

Material of wetted parts: Diaphragm; 316L SST, Others; 316 SST

Reference accuracy *3 *4	Linear output:	$\pm 0.15\%$ (For $x \geq 3.5$ MPa {35 kgf/cm ² }) $\pm \left(0.1 + 0.05 \times \frac{3.5}{x} \right) \%$ (For $x < 3.5$ MPa {35 kgf/cm ² })
	Square-root output:	When output is 50 to 100 %: same as linear output When output is 7.1 to 50 %: linear output $\times \frac{50}{\text{square-root} \cdot \text{output}} \%$ When output is less than 7.1 %: dropout
Ambient Temperature effect (Shift from the set range) Change of 30 °C *3 (Range from -5 to +55 °C)	Combined shift: (including zero and span shifts)	$\pm 0.41\%$ (For $x \geq 3.5$ MPa {35 kgf/cm ² }) $\pm \left(0.18 + 0.23 \times \frac{3.5}{x} \right) \%$ ($x < 3.5$ MPa {35 kgf/cm ² })
Static pressure effect (Shift with respect to Setting range) *3 Change of 7 MPa {70 kgf/cm ² }	Zero shift:	$\pm \left(0.03 + 0.17 \times \frac{7}{x} \right) \%$
	Combined shift: (including zero and span shifts)	$\pm 0.4\%$ (For $x \geq 7$ MPa {70 kgf/cm ² }) $\pm \left(0.03 + 0.37 \times \frac{7}{x} \right) \%$ (For $x < 7$ MPa {70 kgf/cm ² })

Model GTX71D/72D

Material of wetted parts: Diaphragm; 316L SST, Others; 316L SST

Reference accuracy *3 *4	Linear output:	$\pm 0.2\%$ (For $x \geq 3.5$ MPa {35 kgf/cm ² }) $\pm \left(0.15 + 0.05 \times \frac{3.5}{x} \right) \%$ (For $x < 3.5$ MPa {35 kgf/cm ² })
	Square-root output:	When output is 50 to 100 %: same as linear output When output is 7.1 to 50 %: linear output $\times \frac{50}{\text{square-root} \cdot \text{output}} \%$ When output is less than 7.1 %: dropout
Ambient Temperature effect (Shift from the set range) Change of 30 °C *3 (Range from -5 to +55 °C)	Combined shift: (including zero and span shifts)	$\pm 1.20\%$ (For $x \geq 3.5$ MPa {35 kgf/cm ² }) $\pm \left(0.55 + 0.65 \times \frac{3.5}{x} \right) \%$ (For $x < 3.5$ MPa {35 kgf/cm ² })
Static pressure effect (Shift with respect to Setting range) *3 Change of 7 MPa {70 kgf/cm ² }	Zero shift:	$\pm \left(0.03 + 0.295 \times \frac{7}{x} \right) \%$
	Combined shift: (including zero and span shifts)	$\pm \left(0.45 + 0.125 \times \frac{7}{x} \right) \%$ (For $x \geq 7$ MPa {70 kgf/cm ² }) $\pm \left(0.08 + 0.495 \times \frac{7}{x} \right) \%$ (For $x < 7$ MPa {70 kgf/cm ² })

*3. Within a range of $URV \geq 0$ and $LRV \geq 0$.

*4. Reference accuracy at calibrated condition.

MODEL SELECTION**Model GTX15D (Standard type for lowest differential pressure)**

Model No.: GTX_ _D - Selection I (I II III IV V VI VII) - Selection II (I II III IV V VI) - Option

Basic Model No.

Measuring span	0.1 to 2.0 kPa (10 to 200 mmH ₂ O)	GTX15D
----------------	---	--------

Selection I

I	Output	4 to 20 mA (SFN Communication)	A
		4 to 20 mA (HART Communication)	B
		FOUNDATION Fieldbus communication	C
		Digital output (DE communication) *1	D
II	Fill fluid	Regular type (Silicone oil)	A
		For oxygen service (Fluorine oil)	H
III	Material (Meterbody cover, Vent/Drain plugs)	Meterbody cover	Vent/Drain plugs
		SCS14A	316 SST
IV	Material (center body)	316 SST (Diaphragm: 316L SST)	A
V	Process connections	Rc 1/2, with adapter flange	A
		Rc 1/4, with adapter flange	B
		Rc 1/4, without adapter flange	C
		1/2 NPT internal thread, with adapter flange	D
		1/4 NPT internal thread, with adapter flange	E
		1/4 NPT internal thread, without adapter flange	F
VI	Process installation	Vertical piping, top connection	A
		Vertical piping, bottom connection	B
		Horizontal piping, front connection	C
VII	Bolt/nut	304 SST	B
		316 SST *2	D

Selection II

I	Electrical connection	1/2 NPT, Watertight	A
		M20, Watertight *3	B
II	Explosion proof [☆] *4	None	XX
		FM Explosionproof for Division system/Flameproof for Zone system	F1
		FM Intrinsic safety	F2
		FM Nonincendive	F5
		Combination of code F1, F2, and F5	F6
		ATEX Flameproof	A1
		ATEX Intrinsic safety	A2
		IECEx Flameproof	E1
		IECEx Intrinsic safety	E2
		NEPSI Flameproof	N1
		NEPSI Intrinsic safety	N2
NEPSI Type n	N5		
KOSHA Flameproof *5	K1		
III	Indicator	None	X
		With indicator *6	A
IV	Paint *7	Standard	X
		None (316 stainless steel housing)	E
		Corrosion-proof (Urethane)	H
V	Failure alarm	Upper limit of output at abnormal condition	A
		Lower limit of output at abnormal condition	B
		None (for FOUNDATION Fieldbus) *8	X
VI	Mounting bracket	None	X
		CF8 (L form)	1
		CF8M (L form) *2	2

*1. Not applicable for the combination with code A2 "With external Zero/Span adjustment", Q1 "Safety Transmitter" and Q2 "NAMUR NE43 Compliant Output Signal Limits" of Option.

*2. In case this code is selected, code P8 of Option code should be selected.

*3. Not applicable for the combination with code F1, F6 of Explosion proof.

*4. For FOUNDATION Fieldbus type. Refer to SS2-GTX00Z-0100.

*5. Not applicable for the combination with code E of Paint.

*6. In case the code C "FOUNDATION Fieldbus communication" of output is selected, code A2 of Option code should be selected.

*7. In case code X or H is selected, the material of transmitter case is aluminum alloy.

*8. Not applicable for the combination with code A "4 to 20 mA (SFN Communication)", B "4 to 20 mA (HART Communication)", and D "Digital output (DE communication)" of output.

Model No.: GTX__D - Selection I (I II III IV V VI VII) - Selection II (I II III IV V VI) - Option

Option

	No options	XX
	Adapter flange for corrosion-resistant application (316L SST or Tantalum for the wetted parts of centerbody)	A1
	With external Zero/Span adjustment (With external ZERO adjustment only for FOUNDATION Fieldbus)*8 *9	A2
	One elbow (left) *3 *4 *7	G1
	One elbow (right) *3 *4 *7	G2
	2 elbows *3 *5 *7	G3
	Long vent/drain plugs	G4
	Side vent/drain top *3	G6
	Side vent/drain bottom *3	G7
	Oil and water free finish	K1
	Oil free finish *1	K3
	Au Plating Diaphragm	L1
	316 SST (Parts in contact with atmosphere) *11 *12 *13	P8
	Safety Transmitter *2 *9 *14	Q1
	NAMUR NE43 Compliant Output Signal Limits: 3.8 to 20.5 mA (Output 21.6 mA/selected upper limit, 3.6 mA/selected lower limit) *9 *14	Q2
	Alarm Output (contact output) *10 *14	Q7
	Advanced diagnostics *15	Q8
	Custom calibration	R1
	Test report	T1
	Mill certificate	T2
	Traceability certificate	T4
	NACE certificate *6	T5
	Non SI Unit	W1

*1. No need to select when Fill Fluid code H, or J is selected.

*2. Not applicable for the combination with code A2, or Q7 of Option.

*3. Not applicable for the combination with code A, or B of Process installation.

*4. Not applicable for the combination with code F1, F6 of Explosion proof.

*5. Not applicable for any Explosion proof. Please select code XX "None" of Explosion proof.

*6. Applicable for "ASTM B575", code B of Material (center body).

*7. Not applicable for the combination with code B "M20, Watertight" electrical connection.

*8. Not applicable for the combination with code X "None" of Indicator. Please select "With indicator".

*9. Not applicable for the combination with code D "Digital output (DE communication)" of output.

*10. Not applicable for the combination with code F2, F5, F6, N2, N5, E2, and A2 of Explosion proof.

*11. In case code P8 is selected, code D of Bolt/nut should be selected.

*12. In case code P8 is selected, code E of Paint should be selected.

*13. In case code P8 is selected, code X or 2 of Mounting bracket should be selected.

*14. Not applicable for the combination with code C "Digital output (FOUNDATION Fieldbus communication)" of output.

*15. Not applicable for the combination with code A "4 to 20 mA (SFN Communication)", B "4 to 20 mA (HART Communication)", and D "Digital output (DE communication)" of output.

Model GTX30D (Standard type for standard differential pressure)

Model GTX40D (Standard type for high differential pressure)

Model No.: GTX_ _D - Selection I (I II III IV V VI VII) - Selection II (I II III IV V VI) - Option

Basic Model No.

Measuring span	0.5 to 100 kPa (50 to 10160 mmH ₂ O)	GTX30D
	35 to 700 kPa (0.35 to 7 kgf/cm ²)	GTX40D

Selection I

I	Output	4 to 20 mA (SFN Communication)	A
		4 to 20 mA (HART Communication)	B
		FOUNDATION Fieldbus communication	C
		Digital output (DE communication) *1	D
II	Fill fluid	Regular type (Silicone oil)	A
		For oxygen service (Fluorine oil)	H
III	Material (Meterbody cover, Vent/Drain plugs)	Meterbody cover	Vent/Drain plugs
		SCS14A	316 SST A
IV	Material (center body)	316 SST (Diaphragm: 316L SST)	A
		ASTM B575 (Equivalent to Hastelloy C-276)	B
V	Process connections	Rc 1/2, with adapter flange	A
		Rc 1/4, with adapter flange	B
		Rc 1/4, without adapter flange	C
		1/2 NPT internal thread, with adapter flange	D
		1/4 NPT internal thread, with adapter flange	E
		1/4 NPT internal thread, without adapter flange	F
VI	Process installation	Vertical piping, top connection	A
		Vertical piping, bottom connection	B
		Horizontal piping, front connection	C
VII	Bolt/nut	304 SST	B
		316 SST *2	D

Selection II

I	Electrical connection	1/2 NPT, Watertight	A
		M20, Watertight *3	B
II	Explosion proof [☆] *4	None	XX
		FM Explosionproof for Division system/Flameproof for Zone system	F1
		FM Intrinsic safety	F2
		FM Nonincendive	F5
		Combination of code F1, F2, and F5	F6
		ATEX Flameproof	A1
		ATEX Intrinsic safety	A2
		IECEX Flameproof	E1
		IECEX Intrinsic safety	E2
		NEPSI Flameproof	N1
		NEPSI Intrinsic safety	N2
		NEPSI Type n	N5
KOSHA Flameproof *5	K1		
III	Indicator	None	X
		With indicator *6	A
IV	Paint *7	Standard	X
		None (316 stainless steel housing)	E
		Corrosion-proof (Urethane)	H
V	Failure alarm	Upper limit of output at abnormal condition	A
		Lower limit of output at abnormal condition	B
		None (for FOUNDATION Fieldbus) *8	X
VI	Mounting bracket	None	X
		CF8 (L form)	1
		CF8M (L form) *2	2

(Continued)

(Continued from previous page)

- *1. Not applicable for the combination with code A2 “With external Zero/Span adjustment”, Q1 “Safety Transmitter” and Q2 “NAMUR NE43 Compliant Output Signal Limits” of Option.
- *2. In case this code is selected, code P8 of Option code should be selected.
- *3. Not applicable for the combination with code F1, F6 of Explosion proof.
- *4. For FOUNDATION Fieldbus type. Refer to SS2-GTX00Z-0100.
- *5. Not applicable for the combination with code E of Paint.
- *6. In case the code C “FOUNDATION Fieldbus communication” of output is selected, code A2 of Option code should be selected.
- *7. In case code X or H is selected, the material of transmitter case is aluminum alloy.
- *8. Not applicable for the combination with code A “4 to 20 mA (SFN Communication)”, B “4 to 20 mA (HART Communication)”, and D “Digital output (DE communication)” of output.

Model No.: GTX_ _D - Selection I (I II III IV V VI VII) - Selection II (I II III IV V VI) - **Option**

Option

	—
No options	XX
Adapter flange for corrosion-resistant application (316L SST or Tantalum for the wetted parts of centerbody)	A1
With external Zero/Span adjustment (With external ZERO adjustment only for FOUNDATION Fieldbus)*8 *9	A2
One elbow (left) *3 *4 *7	G1
One elbow (right) *3 *4 *7	G2
2 elbows *3 *5 *7	G3
Long vent/drain plugs	G4
Side vent/drain top *3	G6
Side vent/drain bottom *3	G7
Oil and water free finish	K1
Oil free finish *1	K3
Au Plating Diaphragm	L1
316 SST (Parts in contact with atmosphere) *11 *12 *13	P8
Safety Transmitter *2 *9 *14	Q1
NAMUR NE43 Compliant Output Signal Limits: 3.8 to 20.5 mA (Output 21.6 mA/selected upper limit, 3.6 mA/selected lower limit) *9 *14	Q2
Alarm Output (contact output) *10 *14	Q7
Advanced diagnostics *15	Q8
Custom calibration	R1
Test report	T1
Mill certificate	T2
Traceability certificate	T4
NACE certificate *6	T5
Non SI Unit	W1

- *1. No need to select when Fill Fluid code H, or J is selected.
- *2. Not applicable for the combination with code A2, or Q7 of Option.
- *3. Not applicable for the combination with code A, or B of Process installation.
- *4. Not applicable for the combination with code F1, F6 of Explosion proof.
- *5. Not applicable for any Explosion proof. Please select code XX “None” of Explosion proof.
- *6. Applicable for “ASTM B575”, code B of Material (center body).
- *7. Not applicable for the combination with code B “M20, Watertight” electrical connection.
- *8. Not applicable for the combination with code X “None” of Indicator. Please select “With indicator”.
- *9. Not applicable for the combination with code D “Digital output (DE communication)” of output.
- *10. Not applicable for the combination with code F2, F5, F6, N2, N5, E2, and A2 of Explosion proof.
- *11. In case code P8 is selected, code D of Bolt/nut should be selected.
- *12. In case code P8 is selected, code E of Paint should be selected.
- *13. In case code P8 is selected, code X or 2 of Mounting bracket should be selected.
- *14. Not applicable for the combination with code C “Digital output (FOUNDATION Fieldbus communication)” of output.
- *15. Not applicable for the combination with code A “4 to 20 mA (SFN Communication)”, B “4 to 20 mA (HART Communication)”, and D “Digital output (DE communication)” of output.

Model GTX31D (High static pressure type for standard differential pressure)

Model GTX41D (High static pressure type for high differential pressure)

Model GTX71D (High static pressure type for highest differential pressure)

Model No.: GTX__D - Selection I (I II III IV V VI VII) - Selection II (I II III IV V VI) - Option

Basic Model No.

Measuring span	0.5 to 100 kPa (50 to 10160 mmH ₂ O)	GTX31D
	35 to 700 kPa (0.35 to 7 kgf/cm ²)	GTX41D
	0.25 to 14 MPa (2.5 to 140 kgf/cm ²)	GTX71D

Selection I

I	Output	4 to 20 mA (SFN Communication)	A	
		4 to 20 mA (HART Communication)	B	
		FOUNDATION Fieldbus communication	C	
		Digital output (DE communication) *1	D	
II	Fill fluid	Regular type (Silicone oil)	A	
		For oxygen service (Fluorine oil)	H	
		For chlorine service (Fluorine oil) *2	J	
III	Material (Meterbody cover, Vent/Drain plugs)	Meterbody cover	Vent/Drain plugs	
		SCS14A	316 SST	A
		PVC *3 *4	PVC *3 *4 *5 *6	C
IV	Material (center body)	316 SST (Diaphragm: 316L SST)	A	
		ASTM B575 (Equivalent to Hastelloy C-276) *7 *8 *9	B	
		Tantalum *10 *11 *12	C	
		316L SST *10 *11 *12	D	
V	Process connections	Rc 1/2, with adapter flange *5	A	
		Rc 1/4, with adapter flange	B	
		Rc 1/4, without adapter flange	C	
		1/2 NPT internal thread, with adapter flange *5	D	
		1/4 NPT internal thread, with adapter flange	E	
		1/4 NPT internal thread, without adapter flange	F	
VI	Process installation	Vertical piping, top connection *6 *11	A	
		Vertical piping, bottom connection *6 *11	B	
		Horizontal piping, front connection	C	
VII	Bolt/nut	Carbon steel	A	
		304 SST *13	B	
		630 SST	C	
		316 SST *13 *14	D	

Selection II

I	Electrical connection	1/2 NPT, Watertight	A
		M20, Watertight *15	B
II	Explosion proof [☆] *16	None	XX
		FM Explosionproof for Division system/Flameproof for Zone system	F1
		FM Intrinsic safety	F2
		FM Nonincendive	F5
		Combination of code F1, F2, and F5	F6
		ATEX Flameproof	A1
		ATEX Intrinsic safety	A2
		IECEx Flameproof	E1
		IECEx Intrinsic safety	E2
		NEPSI Flameproof	N1
		NEPSI Intrinsic safety	N2
NEPSI Type n	N5		
KOSHA Flameproof *17	K1		
III	Indicator	None	X
		With indicator *18	A
IV	Paint *19	Standard	X
		None (316 stainless steel housing)	E
		Corrosion-proof (Urethane)	H
V	Failure alarm	Upper limit of output at abnormal condition	A
		Lower limit of output at abnormal condition	B
		None (for FOUNDATION Fieldbus) *20	X
VI	Mounting bracket	None	X
		CF8 (L form) *21	1
		CF8M (L form) *14	2
		Carbon steel (Flat form) *22	5
		304 SST (Flat form) *22	6

*1. Not applicable for the combination with code A2 "With external Zero/Span adjustment", Q1 "Safety Transmitter" and Q2 "NAMUR NE43 Compliant Output Signal Limits" of Option.

*2. In case code J is selected, code C "Tantalum" of Material (centerbody) should be selected.

(Continued)

(Continued from previous page)

- *3. 304 SST bolts and nuts material (-B) must be selected when PVC meterbody cover is selected. The max. working pressure is 1.5 MPa.
- *4. In case GTX71D, code C cannot be selected.
- *5. In case PVC is selected, code A, or D of Process connections should be selected.
- *6. In case PVC is selected, code A, or B of Process installation should be selected
- *7. Please select A1 of option, when a wetted parts ASTM B575 of GTX71D is selected for assembling a manifold valve.
- *8. When a wetted parts ASTM B575 of GTX71D is selected, code A or B of process installation should be selected.
- *9. When a wetted parts ASTM B575 of GTX 71D is selected, code D of Bolt/nut cannot be selected.
- *10. In case Manifold valve is used and in case code C, D is used, please select code A1 of Option.
- *11. In case code C, or D is selected, code A, or B of Process installation should be selected.
- *13. When 304/316 SST bolt/nut is selected, max working pressure rating is 10 MPa (100 kgf/cm2).
- *14. In case this code is selected, code P8 of Option code should be selected.
- *15. Not applicable for the combination with code F1, F6 of Explosion proof.
- *16. For FOUNDATION Fieldbus type. Refer to SS2-GTX00Z-0100.
- *17. Not applicable for the combination with code E of Paint.
- *18. In case the code C “FOUNDATION Fieldbus communication” of output is selected, code A2 of Option code should be selected.
- *19. In case code X or H is selected, the material of transmitter case is aluminum alloy.
- *20. Not applicable for the combination with code A “4 to 20 mA (SFN Communication)”, B “4 to 20 mA (HART Communication)”, and D “Digital output (DE communication)” of output.
- *21. Applicable for wetted parts of material (center body); 316 SST (GTX31D, 41D, 71D) and ASTM B575 (GTX31D, 41D).
- *22. Applicable for wetted parts of material (center body); Tantalum (GTX31D, 41D, 71D), 316L SST (GTX31D, 41D, 71D) and ASTM B575 (GTX71D).

Model No.: GTX_ _D - Selection I (I II III IV V VI VII) - Selection II (I II III IV V VI) - Option

Option

	—
No options	XX
Adapter flange for corrosion-resistant application (316L SST or Tantalum for the wetted parts of centerbody)	A1
With external Zero/Span adjustment (With external ZERO adjustment only for FOUNDATION Fieldbus) ^{*8 *9}	A2
One elbow (left) ^{*3 *4 *7}	G1
One elbow (right) ^{*3 *4 *7}	G2
2 elbows ^{*3 *5 *7}	G3
Long vent/drain plugs	G4
Side vent/drain top ^{*3}	G6
Side vent/drain bottom ^{*3}	G7
Oil and water free finish	K1
Oil free finish ^{*1}	K3
Au Plating Diaphragm ^{*16}	L1
316 SST (Parts in contact with atmosphere) ^{*11 *12 *13}	P8
Safety Transmitter ^{*2 *9 *14}	Q1
NAMUR NE43 Compliant Output Signal Limits: 3.8 to 20.5 mA (Output 21.6 mA/selected upper limit, 3.6 mA/selected lower limit) ^{*9 *14}	Q2
Alarm Output (contact output) ^{*10 *14}	Q7
Advanced diagnostics ^{*15}	Q8
Custom calibration	R1
Test report	T1
Mill certificate	T2
Traceability certificate	T4
NACE certificate ^{*6}	T5
Non SI Unit	W1

- *1. No need to select when Fill Fluid code H, or J is selected.
- *2. Not applicable for the combination with code A2, or Q7 of Option.
- *3. Not applicable for the combination with code A, or B of Process installation.
- *4. Not applicable for the combination with code F1, F6 of Explosion proof.
- *5. Not applicable for any Explosion proof. Please select code XX “None” of Explosion proof.
- *6. Applicable for “ASTM B575”, code B of Material (center body).
- *7. Not applicable for the combination with code B “M20, Watertight” electrical connection.
- *8. Not applicable for the combination with code X “None” of Indicator. Please select “With indicator”.
- *9. Not applicable for the combination with code D “Digital output (DE communication)” of output.
- *10. Not applicable for the combination with code F2, F5, F6, N2, N5, E2, and A2 of Explosion proof.
- *11. In case code P8 is selected, code D of Bolt/nut should be selected.
- *12. In case code P8 is selected, code E of Paint should be selected.
- *13. In case code P8 is selected, code X or 2 of Mounting bracket should be selected.
- *14. Not applicable for the combination with code C “Digital output (FOUNDATION Fieldbus communication)” of output.
- *15. Not applicable for the combination with code A “4 to 20 mA (SFN Communication)”, B “4 to 20 mA (HART Communication)”, and D “Digital output (DE communication)” of output.
- *16. Not applicable for the combination with “Tantalum” of diaphragm material..

Model GTX32D (High static pressure type for standard differential pressure)

Model GTX42D (High static pressure type for high differential pressure)

Model GTX72D (High static pressure type for highest differential pressure)

Model No.: GTX__D - Selection I (I II III IV V VI VII) - Selection II (I II III IV V VI) - Option

Basic Model No.

Measuring span	0.5 to 100 kPa (50 to 10160 mmH ₂ O)	GTX32D
	35 to 700 kPa (0.35 to 7 kgf/cm ²)	GTX42D
	0.25 to 14 MPa (2.5 to 140 kgf/cm ²)	GTX72D

Selection I

I	Output	4 to 20 mA (SFN Communication)	A
		4 to 20 mA (HART Communication)	B
		FOUNDATION Fieldbus communication	C
		Digital output (DE communication) *1	D
II	Fill fluid	Regular type (Silicone oil)	A
		For oxygen service (Fluorine oil)	H
III	Material (Meterbody cover, Vent/Drain plugs)	Meterbody cover	Vent/Drain plugs
		SCS14A	316 SST
IV	Material (center body)	316 SST (Diaphragm: 316L SST)	
V	Process connections	Rc 1/2, with adapter flange, for high pressure model	P
		Rc 1/4, with adapter flange, for high pressure model	R
		Rc 1/4, without adapter flange, for high pressure model	S
		1/2 NPT internal thread, with adapter flange, for high pressure model	T
		1/4 NPT internal thread, with adapter flange, for high pressure model	W
		1/4 NPT internal thread, without adapter flange, for high pressure model	Y
VI	Process installation	Vertical piping, top connection	A
		Vertical piping, bottom connection	B
		Horizontal piping, front connection	C
VII	Bolt/nut	Carbon steel	A
		304 SST *2	B
		630 SST	C
		316 SST *2 *3	D

Selection II

I	Electrical connection	1/2 NPT, Watertight	A
		M20, Watertight *4	B
II	Explosion proof [☆] *5	None	XX
		FM Explosionproof for Division system/Flameproof for Zone system	F1
		FM Intrinsic safety	F2
		FM Nonincendive	F5
		Combination of code F1, F2, and F5	F6
		ATEX Flameproof	A1
		ATEX Intrinsic safety	A2
		IECEX Flameproof	E1
		IECEX Intrinsic safety	E2
		NEPSI Flameproof	N1
		NEPSI Intrinsic safety	N2
		NEPSI Type n	N5
		KOSHA Flameproof *6	K1
III	Indicator	None	X
		With indicator *7	A
IV	Paint *8	Standard	X
		None (316 stainless steel housing)	E
		Corrosion-proof (Urethane)	H
V	Failure alarm	Upper limit of output at abnormal condition	A
		Lower limit of output at abnormal condition	B
		None (for FOUNDATION Fieldbus) *9	X
VI	Mounting bracket	None	X
		CF8 (L form)	1
		CF8M (L form) *3	2

(Continued)

(Continued from previous page)

- *1. Not applicable for the combination with code A2 “With external Zero/Span adjustment”, Q1 “Safety Transmitter” and Q2 “NAMUR NE43 Compliant Output Signal Limits” of Option.
- *2. When 304/316 SST bolt/nut is selected, max working pressure rating is 20 MPa (200 kgf/cm²).
- *3. In case this code is selected, code P8 of Option code should be selected.
- *4. Not applicable for the combination with code F1, F6 of Explosion proof.
- *5. For FOUNDATION Fieldbus type. Refer to SS2-GTX00Z-0100.
- *6. Not applicable for the combination with code E of Paint.
- *7. In case the code C “FOUNDATION Fieldbus communication” of output is selected, code A2 of Option code should be selected.
- *8. In case code X or H is selected, the material of transmitter case is aluminum alloy.
- *9. Not applicable for the combination with code A “4 to 20 mA (SFN Communication)”, B “4 to 20 mA (HART Communication)”, and D “Digital output (DE communication)” of output.

Model No.: GTX_ _D - Selection I (I II III IV V VI VII) - Selection II (I II III IV V VI) - Option

Option

	—	
No options		XX
Adapter flange for corrosion-resistant application (316L SST or Tantalum for the wetted parts of centerbody)		A1
With external Zero/Span adjustment (With external ZERO adjustment only for FOUNDATION Fieldbus) ^{*8 *9}		A2
One elbow (left) ^{*3 *4 *7}		G1
One elbow (right) ^{*3 *4 *7}		G2
2 elbows ^{*3 *5 *7}		G3
Long vent/drain plugs		G4
Side vent/drain top ^{*3}		G6
Side vent/drain bottom ^{*3}		G7
Oil and water free finish		K1
Oil free finish ^{*1}		K3
Au Plating Diaphragm		L1
316 SST (Parts in contact with atmosphere) ^{*11 *12 *13}		P8
Safety Transmitter ^{*2 *9 *14}		Q1
NAMUR NE43 Compliant Output Signal Limits: 3.8 to 20.5 mA (Output 21.6 mA/selected upper limit, 3.6 mA/selected lower limit) ^{*9 *14}		Q2
Alarm Output (contact output) ^{*10 *14}		Q7
Advanced diagnostics ^{*15}		Q8
Custom calibration		R1
Test report		T1
Mill certificate		T2
Traceability certificate		T4
NACE certificate ^{*6}		T5
Non SI Unit		W1

- *1. No need to select when Fill Fluid code H, or J is selected.
- *2. Not applicable for the combination with code A2, or Q7 of Option.
- *3. Not applicable for the combination with code A, or B of Process installation.
- *4. Not applicable for the combination with code F1, F6 of Explosion proof.
- *5. Not applicable for any Explosion proof. Please select code XX “None” of Explosion proof.
- *6. Applicable for “ASTM B575”, code B of Material (center body).
- *7. Not applicable for the combination with code B “M20, Watertight” electrical connection.
- *8. Not applicable for the combination with code X “None” of Indicator. Please select “With indicator”.
- *9. Not applicable for the combination with code D “Digital output (DE communication)” of output.
- *10. Not applicable for the combination with code F2, F5, F6, N2, N5, E2, and A2 of Explosion proof.
- *11. In case code P8 is selected, code D of Bolt/nut should be selected.
- *12. In case code P8 is selected, code E of Paint should be selected.
- *13. In case code P8 is selected, code X or 2 of Mounting bracket should be selected.
- *14. Not applicable for the combination with code C “Digital output (FOUNDATION Fieldbus communication)” of output.
- *15. Not applicable for the combination with code A “4 to 20 mA (SFN Communication)”, B “4 to 20 mA (HART Communication)”, and D “Digital output (DE communication)” of output.

DIMENSIONS

Model GTX 31D/41D (Material (center body): 316 SST, ASTM B575)

Model GTX 71D (Material (center body): 316 SST)

Process connection: Front side

Unit: mm

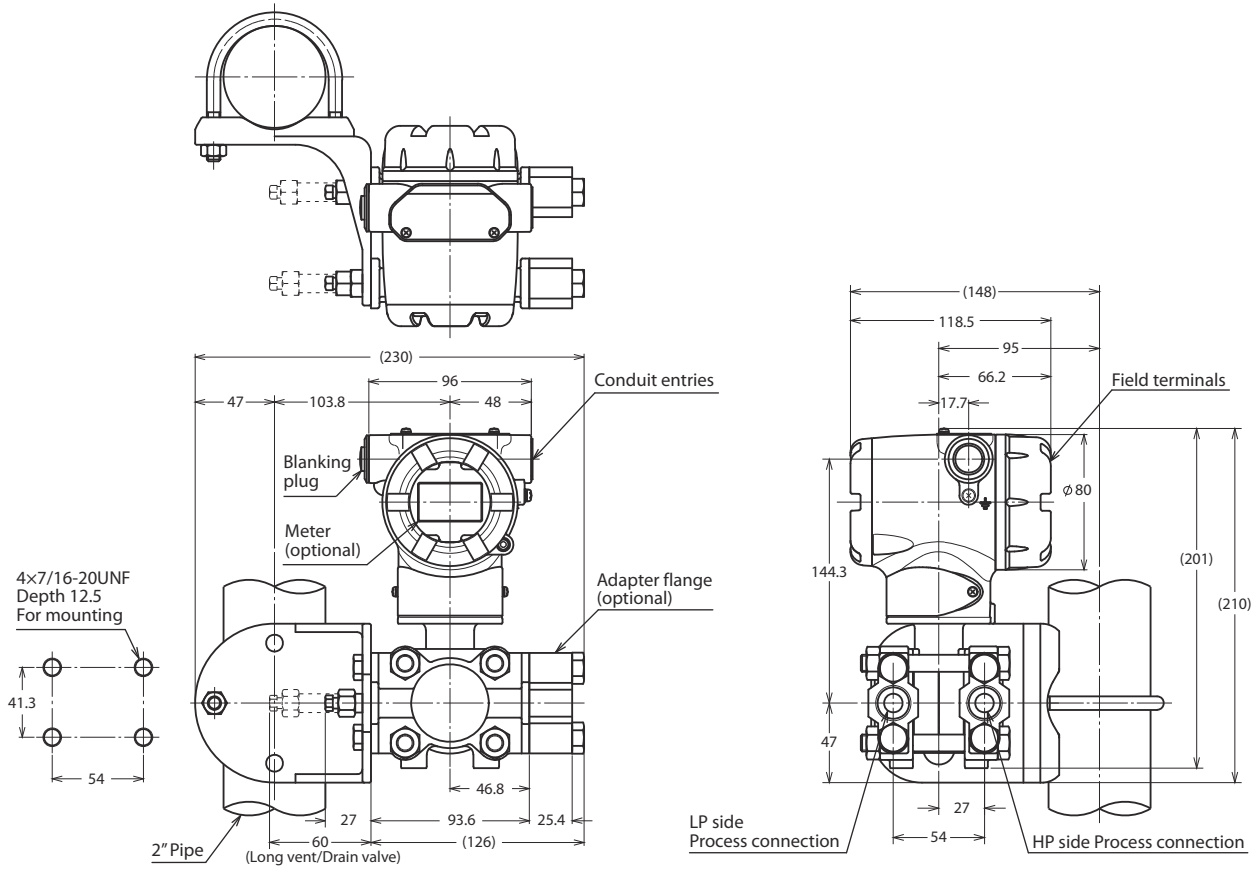

Process Connection: Top or bottom side

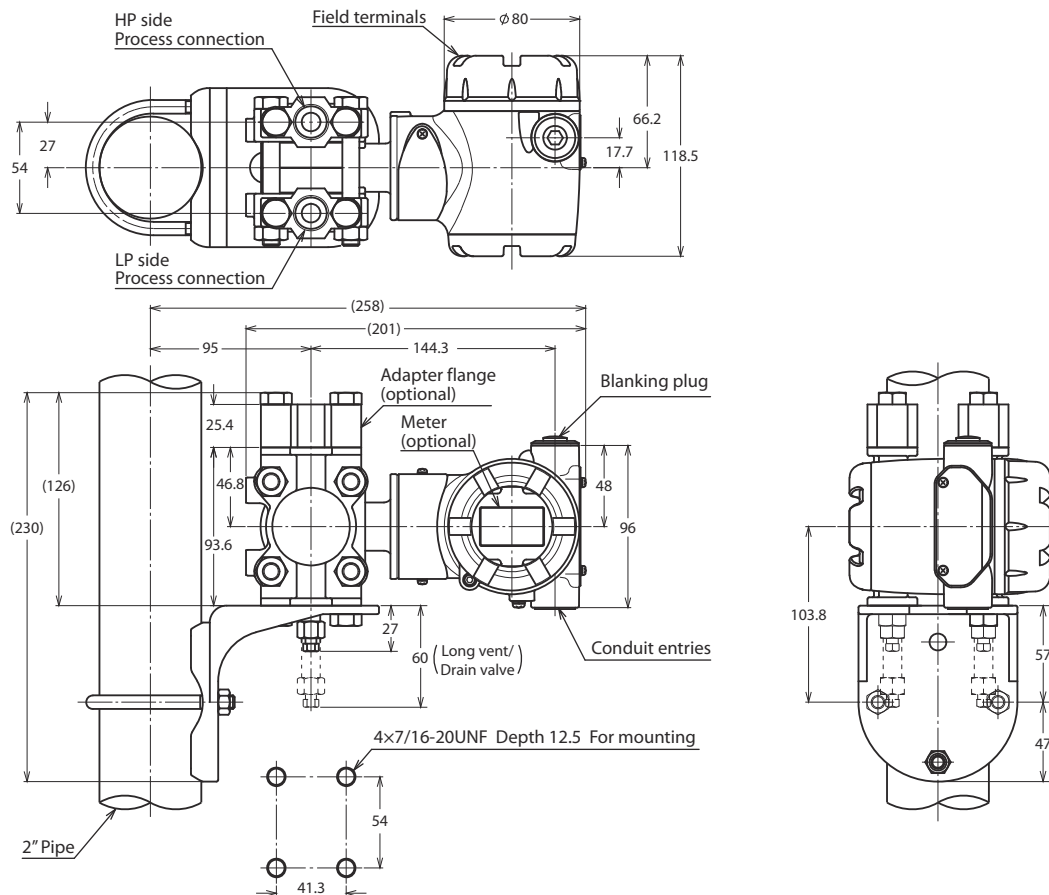

Model GTX 15D (Material (center body): 316 SST)

Model GTX 30D/40D (Material (center body): 316 SST, ASTM B575)

Process connection: Front side

Unit: mm

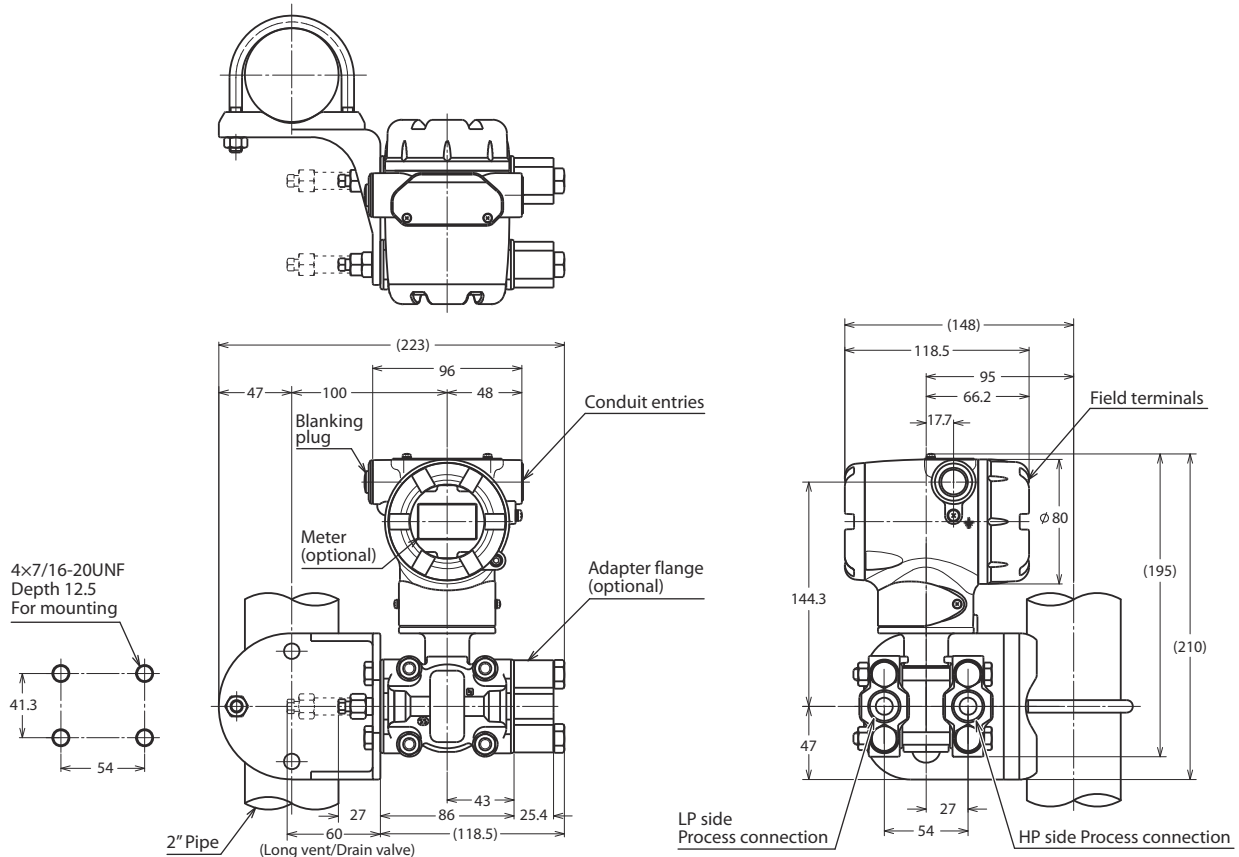

Process Connection: Top or bottom side

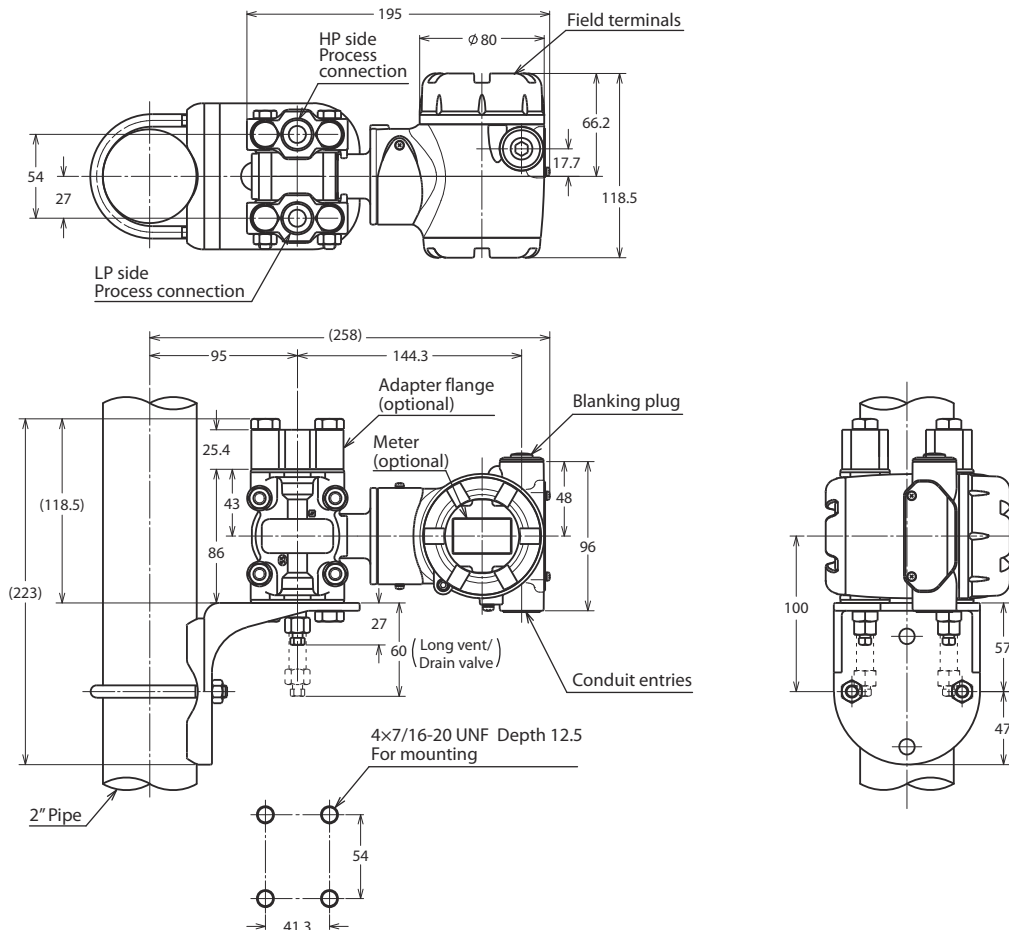

Model GTX 32D/42D/72D

Process connection: Front side

Unit: mm

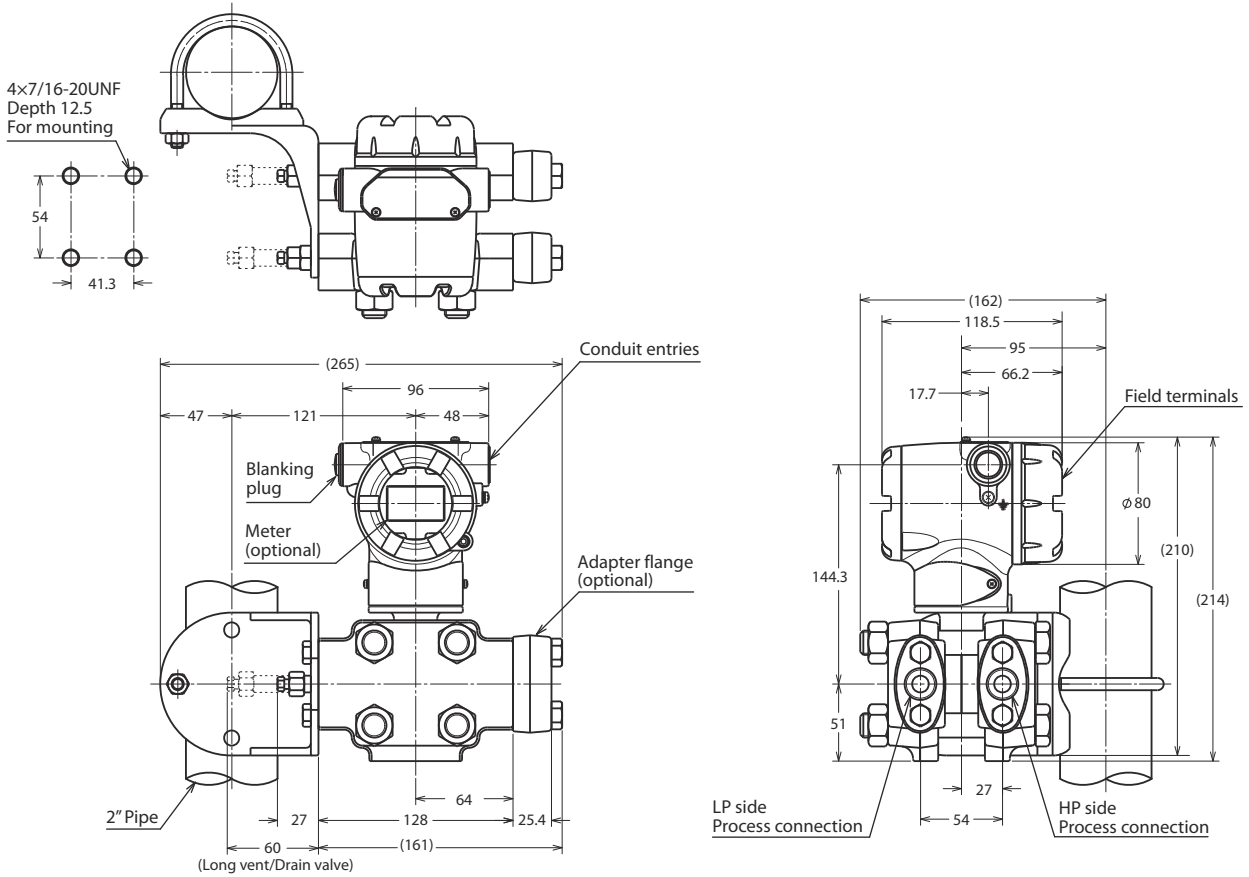

Process Connection: Top side

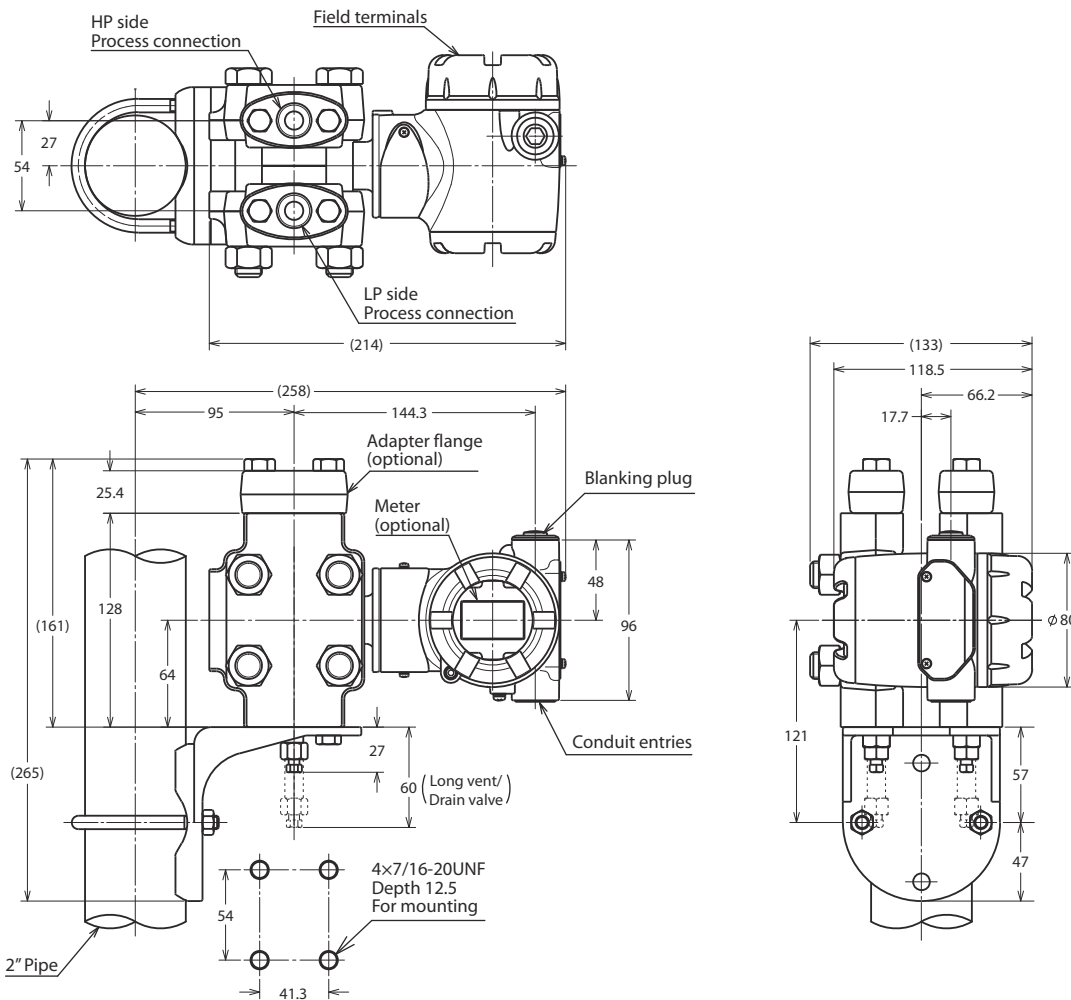

Process Connection: Bottom side

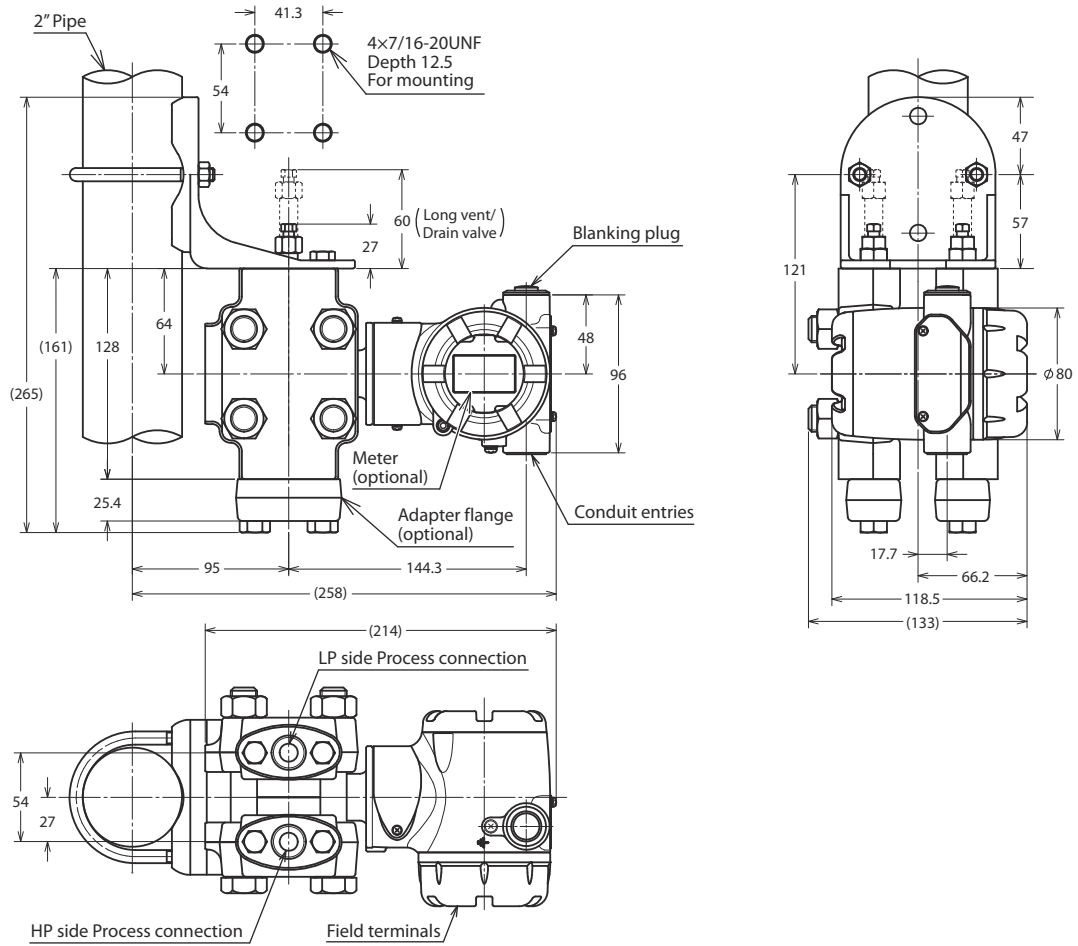

Model GTX 31D/41D (Material (center body): Tantalum, 316L SST)
Model GTX 71D (Material (center body): Tantalum, 316L SST, ASTM B575)

Process connection: Front side

Unit: mm

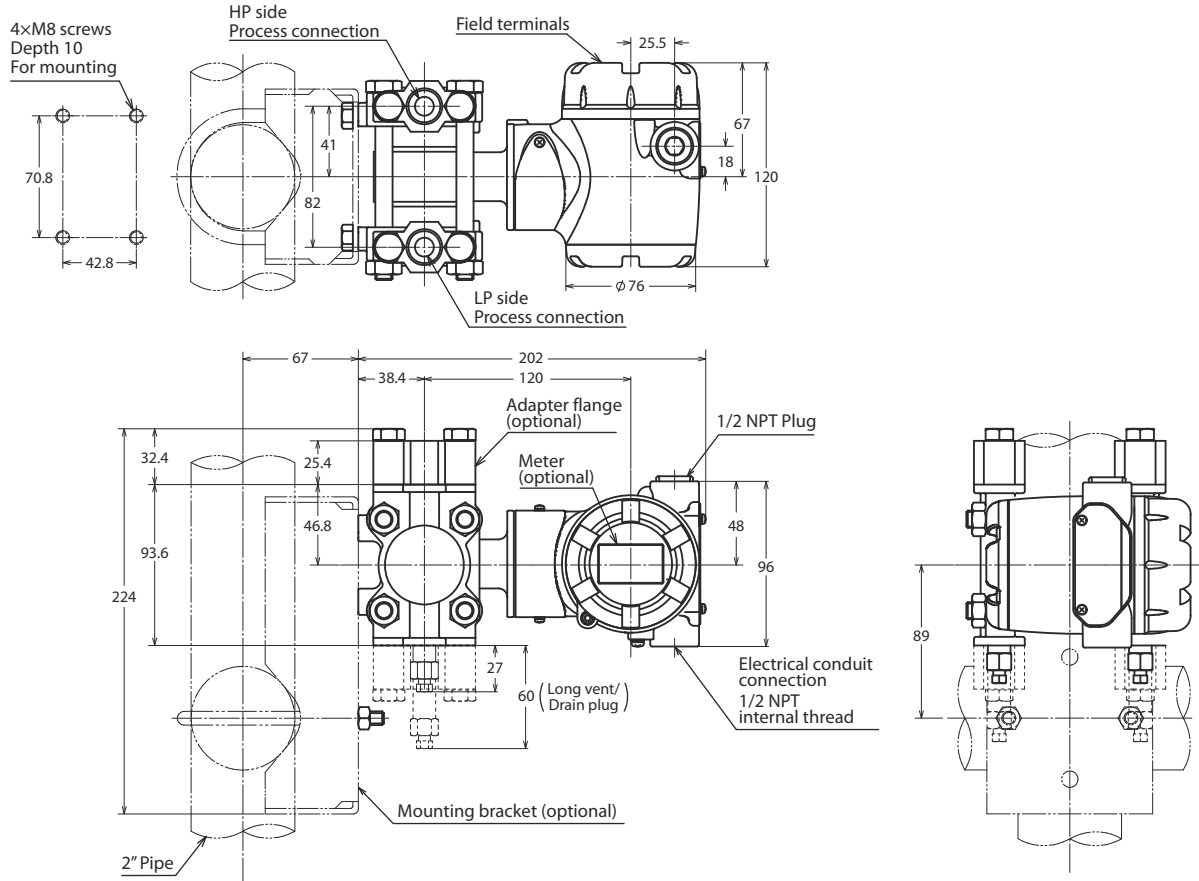

GTX 31D/41D (Material (Meter body cover, Vent/Drain plugs: PVC)

Unit: mm

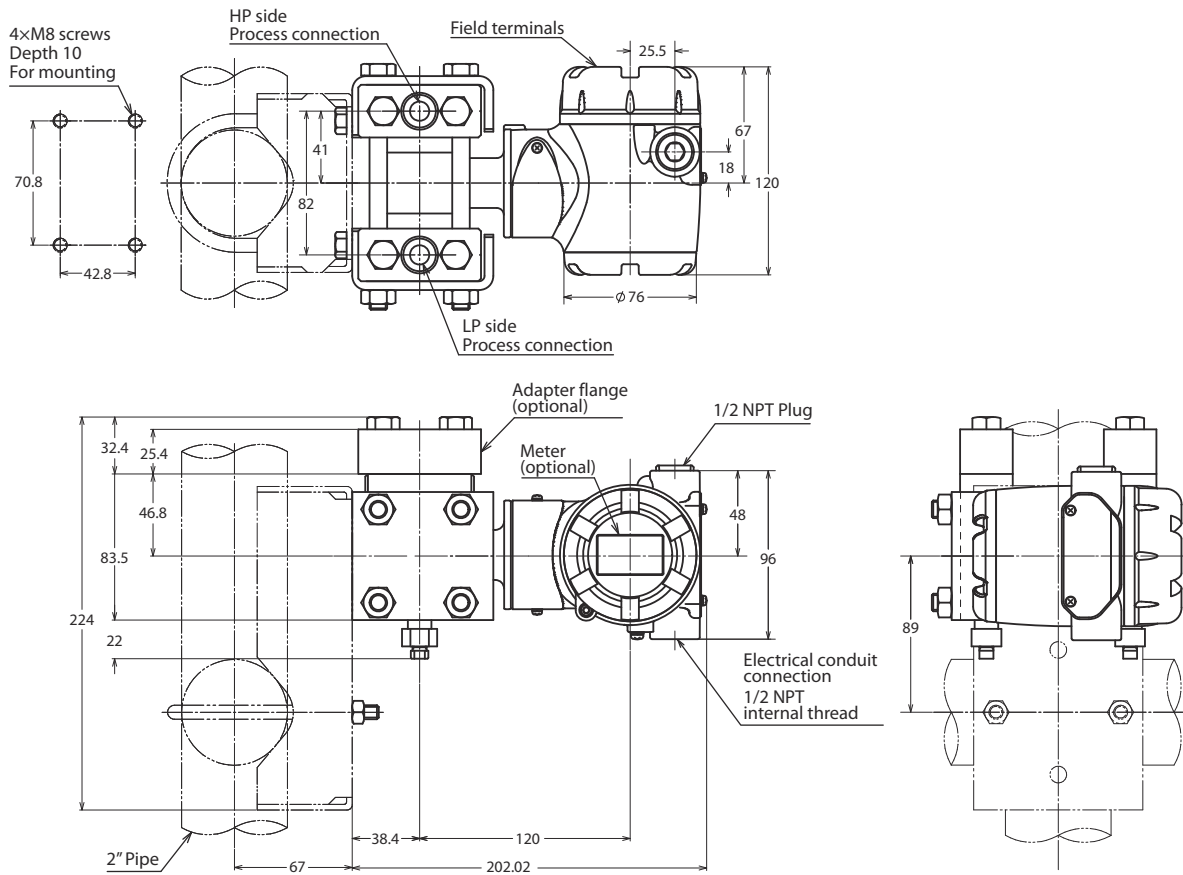

TERMINAL CONNECTION

(Not applicable for Fieldbus. See SS2-GTX00Z-0100 for Fieldbus.)

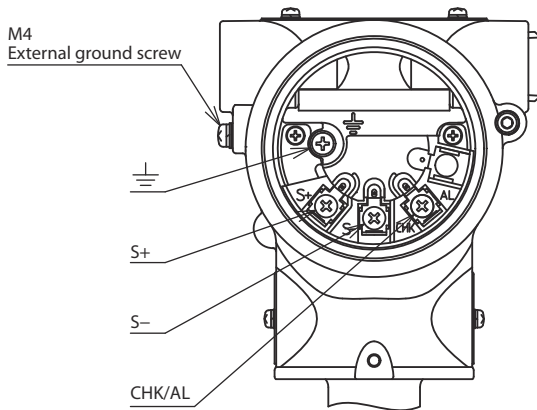

Table 1: Terminal connection

Symbol	Details
S+	Power supply and output signal +
S-	Power supply and output signal -/Check meter -
CHK/AL	Check meter +
⏏	Ground

Table 2: Terminal connection (option "Q7": Alarm output)

Symbol	Details
S+	Power supply and output signal +
S-	Power supply and output signal -
CHK/AL	Alarm +
⏏	Ground/Alarm -

Please, read 'Terms and Conditions' from following URL before the order and use.
<http://www.azbil.com/products/factory/order.html>

Specifications are subject to change without notice.



Azbil Corporation
 Advanced Automation Company

1-12-2 Kawana, Fujisawa
 Kanagawa 251-8522 Japan
 URL: <http://www.azbil.com/>

1st edition: May 2008
 20th edition: Apr. 2017

No part of this publication may be reproduced or duplicated without the prior written permission of Azbil Corporation.