

Restriction Orifice BLS 100 R

Application

Restriction orifices are used to generate a defined pressure loss in process piping or blow out lines. In special cases they may be designed to limit the flow to a specific value. Restriction orifices are applicable for all one-phase fluids.

Design

Restriction orifices are normally designed as a simple plate with an attached tag handle. This plate is mounted between pipe flanges and can be offered for all existing types of flange faces. Restriction orifices may also be designed as a weld-in component.

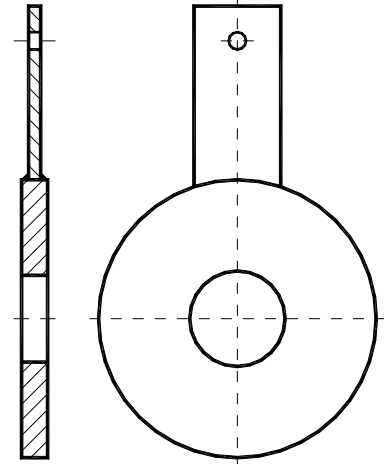

If the plant dictates limits to the noise level or if the pressure loss could lead to cavitation it may be recommendable to use a multihole or multistage restriction orifice. A combination of multihole and multistage design is also possible. For most materials we also offer stellite or other hardfacing of the orifice bore hole in order to achieve a higher durability and therefore a longer service life time.

Calculation

The calculation of the orifice bore hole is based on the well-known standard ISO 5167 for differential pressure flow measurement. The calculated pressure loss is only valid for the given operation point. Therefore, a restriction orifice should not be used for process control. We calculate the noise level in dB(A) based on the standards VDMA 24422 and 24423.

Plate Sealing Surface

according to EN 1092-1:

- flat (form B1 and B2)
- groove (form D)
- tongue (form C)
- female (form E)
- male (form E)

according to ASME B16.5:

- flat (RF and SF)
- groove (small/large)
- tongue (small/large)
- male/female (small/large)
- RTJ male or female

or according to other flange standards specified by the customer.

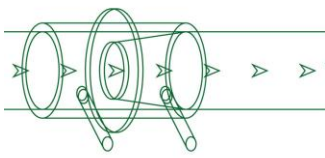
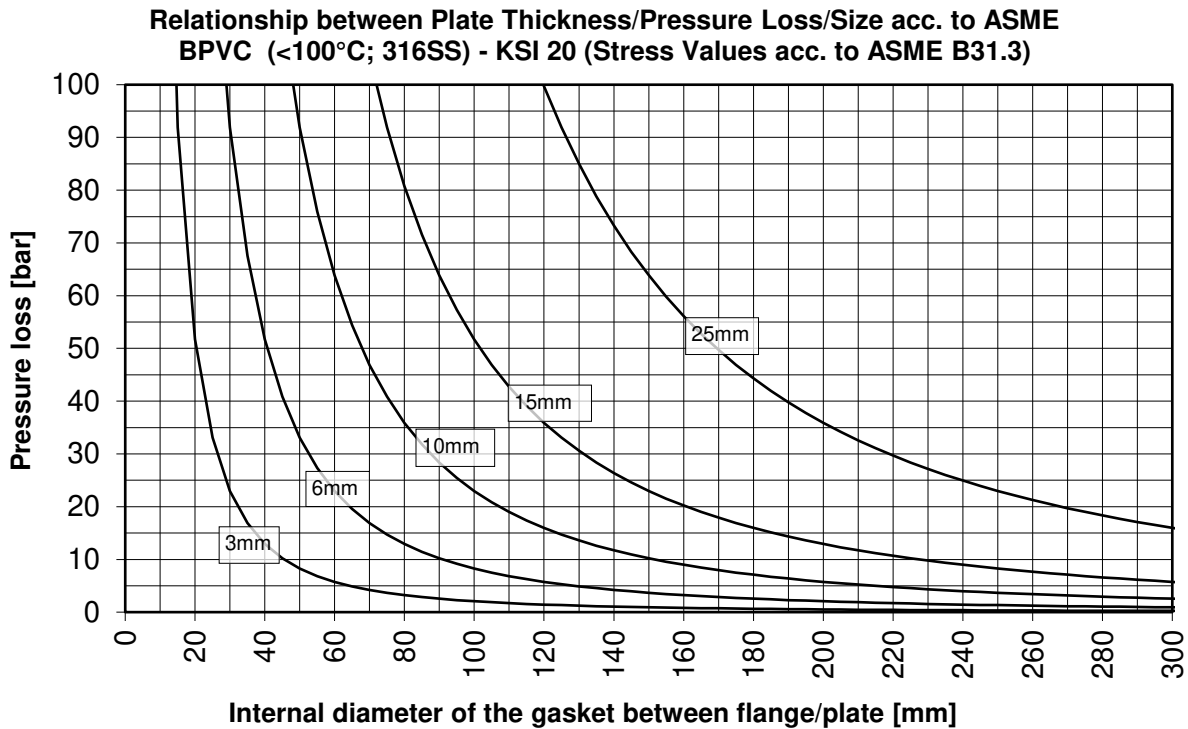

Plate Thickness

The plate thickness of the restrictions orifices is chosen taking into account the plate dimensions, material, pressure loss and temperature. We calculate the plate dimensions according to the valid AD 2000 codes, EN standards or ASME standards (see example diagram below). For low additional charge we include calculation details in your order.



© Alle Rechte vorbehalten - All rights reserved

Installation

For mounting between flanges according to EN 1092-1 / ASME B 16.5 or other standard such as DIN, JIS or BS. The pipe may be positioned horizontally, vertically or sloped.

Techn. Stand 04-2016

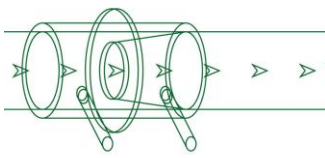

Design Types

for mounting between flanges

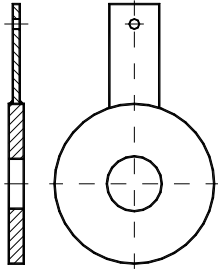

single step/hole
restriction orifice

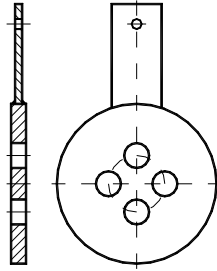

single step multihole
restriction orifice

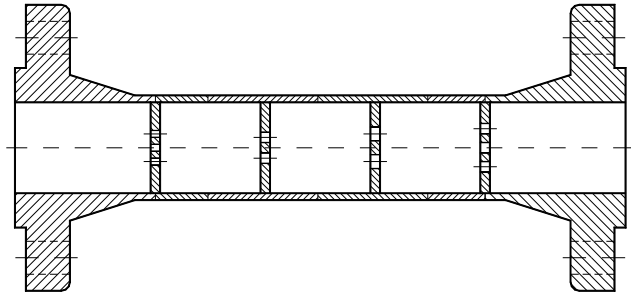

multistep multihole
restriction orifice

for weld-in

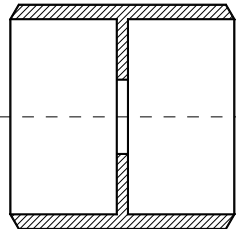

single step restriction orifice

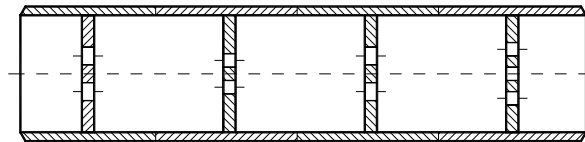

multistep multihole restriction orifice

Quality Control

Manufacture and Test work is done according to the relevant codes and standards such as AD 2000, EN 13480, ASME Codes (without stamp) or customer specifications. Inspection certificates according to EN 10204 3.1 and 3.2. may be furnished. Special inspections are also possible.

Accessories

Pipe flanges, screws and gaskets are not part of the usual scope. However, if needed they may be offered for additional charges.